



AK4187

Touch Screen Controller for Dual Touch Gestures

GENERAL DESCRIPTION

The AK4187 is a 4-wire resistive touch screen controller with an integrated 12-bit SAR A/D converter, and it is capable of supporting dual touch gestures. The AK4187 can detect both the pressed screen location and touch pressure. It can also detect the dual touch center location and the parameters related to two touch points distance. The AK4187 is available in a 16pin QFN, and it is ideal for touch screens for mobile phones, DSC, DVC, smart phones, and other portable devices. And the AK4187 is available in a 16pin QFN package and a 16pin TSSOP package for automotive devices.

FEATURES

- 4-wire Touch Screen Interface
- I²C Serial Interface
- 12bit SAR A/D Converter with S/H circuit
- Dual Touch Functions
 - Dual Touch Judgment
 - Dual Touch Information Outputs
 - (1) Center Location
 - (2) Parameter that Related to Dual Touch Distance
- Pen Pressure Measurement
- Continuous Read Function
- Integrated Internal Osc (Sequence Mode)
- Integrated Median Averaging Filter
- Low Voltage Operation: VDD = 2.7V ~ 3.6V
TVDD = 1.6V ~ 3.6V (Digital I/F)
- PENIRQN Buffer Output
- General Purpose Analog Input
- Low Power Consumption: typ. 250uA @ 450Hz
- Auto Power Down
- Ta = -40 ~ 85 °C
- Package: 16pin QFN (3.0mm x 3.0mm, pitch 0.5mm)
16pin TSSOP (5.0mm x 4.4mm, pitch 0.65mm)

I²C-bus is a trademark of NXP B.V.

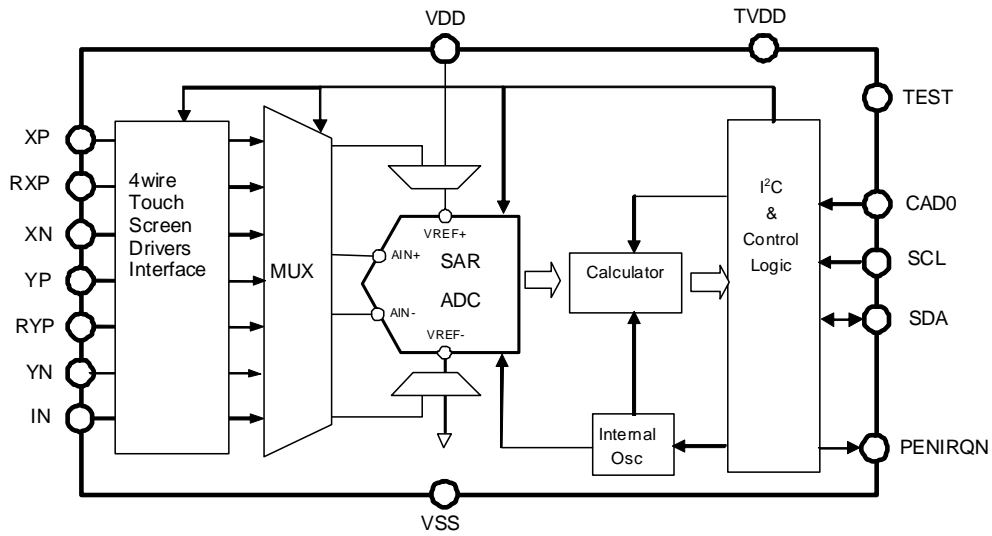

Figure 1. Block Diagram

■ Ordering Guide

AK4187EN	-40 ~ +85°C	16pin QFN (3.0mm x 3.0mm, 0.5mm pitch)
AK4187VN	-40 ~ +85°C	16pin QFN (3.0mm x 3.0mm, 0.5mm pitch)
AK4187AKT	-40 ~ +85°C	16pin TSSOP (5.0mm x 4.4mm, 0.65mm pitch)
AKD4187	AK4187EN Evaluation Board	
AKD4187VN	AK4187VN Evaluation Board	
AKD4187A	AK4187AKT Evaluation Board	

■ Pin Layout

AK4187EN

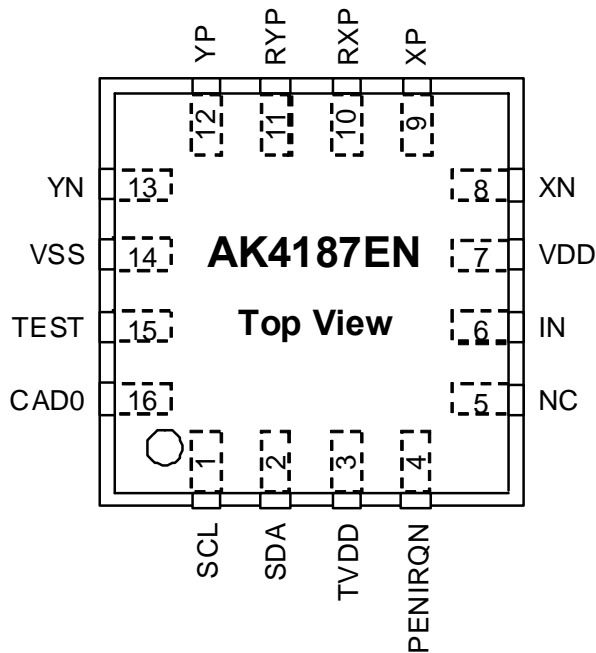

AK4187VN

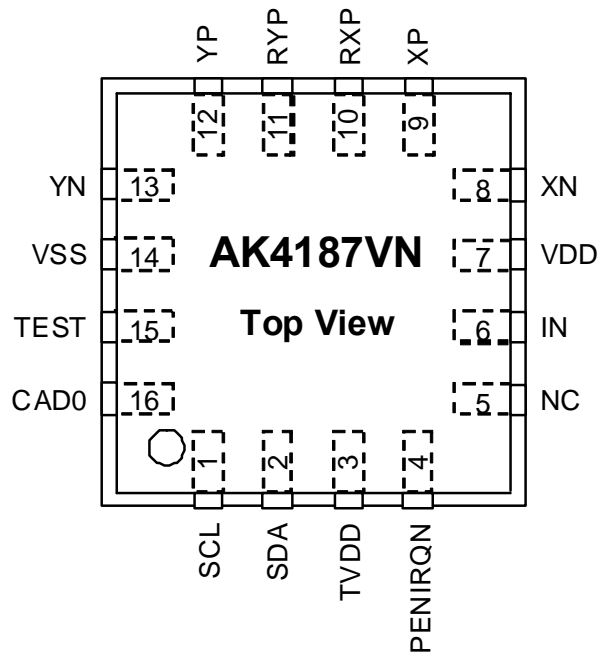

AK4187AKT

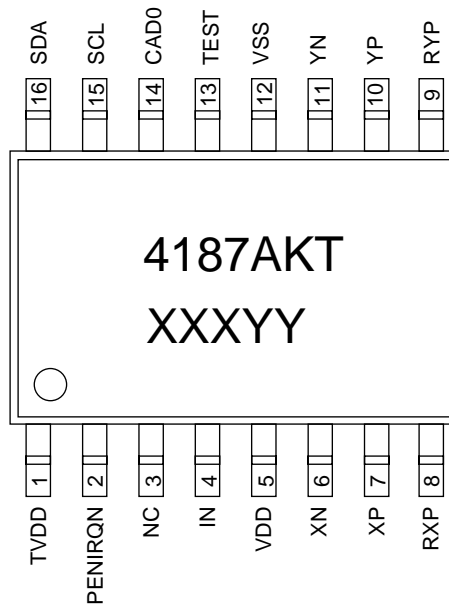

PIN/FUNCTION

Pin No.		Pin Name	I/O	Function
EN/VN	AKT			
1	15	SCL	I	I ² C Serial Clock Input
2	16	SDA	I/O	I ² C Serial Data Input/ Output
3	1	TVDD	-	Digital I/F Power Supply : 1.6V ~ 3.6V
4	2	PENIRQN	O	Pen Interrupt Output (CMOS output) The PENIRQN pin is "L" when touch-screen press is detected. This pin is always "H" or "Hi-z" irrespective of touch-press in sleep mode. This pin acts as "Busy"(active low) in internal calculations.
5	3	NC	-	No Connection. No internal bonding. This pin must be connected to VSS
6	4	IN	I	Auxiliary Analog Input
7	5	VDD	-	Power Supply and External Reference Input: 2.7V ~ 3.6V
8	6	XN	I/O	Touch Panel X- Input Touch Panel X- Driver pin through a resistor for dual touch
9	7	XP	I/O	Touch Panel X+ Input Touch Panel X+ Driver pin
10	8	RXP	O	Touch Panel X+ Driver pin through a resistor for dual touch
11	9	RYP	O	Touch Panel Y+ Driver pin through a resistor for dual touch
12	10	YP	I/O	Touch Panel Y+ Input Touch Panel Y+ Driver pin
13	11	YN	I/O	Touch Panel Y- Input Touch Panel Y- Driver pin through a resistor for dual touch
14	12	VSS	-	Ground
15	13	TEST	I	TEST pin This pin must be connected to VSS or open. TEST pin has internal pull-down device, nominally 100 kΩ
16	14	CAD0	I	I ² C Slave Address bit 0

Note 1. All digital input pins (CAD0, SCL, SDA) must not be allowed to float.

■ Handling of Unused Pin

The unused I/O pin must be processed appropriately as below.

Classification	Pin Name	Setting
Analog	IN	This pin must be open

ABSOLUTE MAXIMUM RATINGS

(VSS = 0V (Note 2))

Parameter	Symbol	min	max	Unit
Power Supply	VDD	-0.3	4.6	V
	TVDD	-0.3	4.6	V
Input Current Any Pins except for supply	IIN	-	±10	mA
Touch Panel Drive Current	IOU DRV	-	50	mA
Analog Input Voltage (Note 3)	VINA	-0.3	VDD+0.3 or 4.6	V
Digital Input Voltage (Note 4)	VIND	-0.3	TVDD+0.3 or 4.6	V
Ambient Temperature (power applied)	Ta	-40	85	°C
Storage Temperature	Tstg	-65	150	°C

Note 2. All voltages with respect to ground

Note 3. XP, XN, YP, YN, RXP, RYP and IN pins. The maximum value is smaller value between (VDD+0.3) V and 4.6V.

Although the RXP and RYP pins are not input pins, it is necessary to set the minimum and maximum ratings of the input voltage as they are connected to the XP and YP pins respectively via a resistor.

Note 4. CAD0, SCL, SDA and TEST pins. The maximum value is smaller value between (VDD+0.3) V and 4.6V.

WARNING: Operation at or beyond these limits may result in permanent damage to the device.

Normal operation is not guaranteed at these extremes.

RECOMMEND OPERATING CONDITIONS

(VSS = 0V (Note 2))

Parameter		Symbol	min	typ	max	Unit
Power Supply	Analog, Calculator	VDD	2.7	3.0	3.6	V
	Digital I/F (Note 5)	TVDD	1.6	1.8	VDD	V

Note 2. All voltages with respect to ground

Note 5. CAD0, SCL, SDA, PENIRQN and TEST pins.

WARNING: AKM assumes no responsibility for the usage beyond the conditions in this datasheet.

ANALOG CHARACTERISTICS(Ta = -40°C to 85°C, VDD = 3.0V, TVDD = 1.8V, I²C bus SCL=400kHz)

Parameter	min	typ	max	Unit
A/D Converter				
Resolution	-	12	-	Bits
No Missing Codes	11	-	-	Bits
Integral Nonlinearity (INL) Error	-	-	±2	LSB
Differential Nonlinearity (DNL) Error	-	±1	+3/-2	LSB
Offset Error	-	-	±6	LSB
Gain Error	-	-	±4	LSB
Touch Panel Drivers Switch On-Resistance				
XP, YP : RL = 300Ω	2.5	6	12	Ω
XN, YN : RL = 300Ω	2.5	6	12	Ω
RXP, RYP : RL = 450Ω	95	126	180	Ω
PENIRQN Pull Up Resistance	30	50	70	kΩ
Auxiliary IN Input				
Input Voltage Range	0	-	VDD	V
Power Supply Current				
VDD Power Current 1 (1 touch mode, COUNT bit = "1") (Note 6)	-	170	-	uA
VDD Power Current 2 (2 touch mode, COUNT bit = "0") (Note 7)	-	240	395	uA
TVDD Power Current	-	10	16	uA
Full Power Down (SDA = SCL = "H", No-touch)	-	0	5	uA

Note 6. SEQM3-0 bits = "0000". Write command period = 1.1ms (SEQM Write => Measurement => Register Read).
Expect for Power Consumption of Touch Panel driver.

Note 7. SEQM3-0 bits = "1010" and INTERVALR = "100". Write command period = 2.2ms (SEQM Write => Measurement => Register Read). Expect for Power Consumption of Touch Panel driver.

DC CHARACTERISTICS (Logic I/O)

(Ta = -40°C to 85°C, VDD = 2.7V to 3.6V, TVDD = 1.6V to 3.6V)

Parameter	Symbol	min	typ	max	Unit
"H" level input voltage	VIH	0.8xTVDD	-	-	V
"L" level input voltage	VIL	-	-	0.2xTVDD	V
Digital Input/Tri-state Leakage Current (Note 8)	IILK	-10	-	10	μA
"H" level output voltage (PENIRQN pin @ Iout = -250μA)	VOH	TVDD-0.3	-	-	V
"L" level output voltage (PENIRQN pin @ Iout = 250μA) (SDA pin @ Iout = 3mA)	VOL	-	-	0.3	V
Analog Input/Tri-state Leakage Current	IOLK	-3	-	3	μA

Note 8. Expect for TEST pin.

SWITCHING CHARACTERISTICS

(Ta=-40°C to 85°C, VDD = 2.7V to 3.6V, TVDD = 1.6V to 3.6V)

Parameter	Symbol	min	typ	max	Unit
Internal Oscillator					
Clock frequency	fosc	2.5	3.6	5.1	MHz
Touch Panel (A/D Converter)					
SCL clock frequency	fSCL	-	-	400	kHz
Bus Free Time Between Transmissions	tBUF	1.3	-	-	μs
Start Condition Hold Time (prior to first Clock pulse)	tHD:STA	0.6	-	-	μs
Clock Low Time	tLOW	1.3	-	-	μs
Clock High Time	tHIGH	0.6	-	-	μs
Setup Time for Repeated Start Condition	tSU:STA	0.6	-	-	μs
SDA Hold Time from SCL Falling (Note 9)	tHD:DAT	0	-	-	μs
SDA Setup Time from SCL Rising	tSU:DAT	0.1	-	-	μs
Rise Time of Both SDA and SCL Lines	tR	-	-	0.3	μs
Fall Time of Both SDA and SCL Lines	tF	-	-	0.3	μs
Setup Time for Stop Condition	tSU:STO	0.6	-	-	μs
Pulse Width of Spike Noise Suppressed By Input Filter	tSP	-	-	50	ns
Capacitive load on bus	Cb	-	-	400	pF

Note 9: Data must be held for sufficient time to bridge the 300ns transition time of SCL.

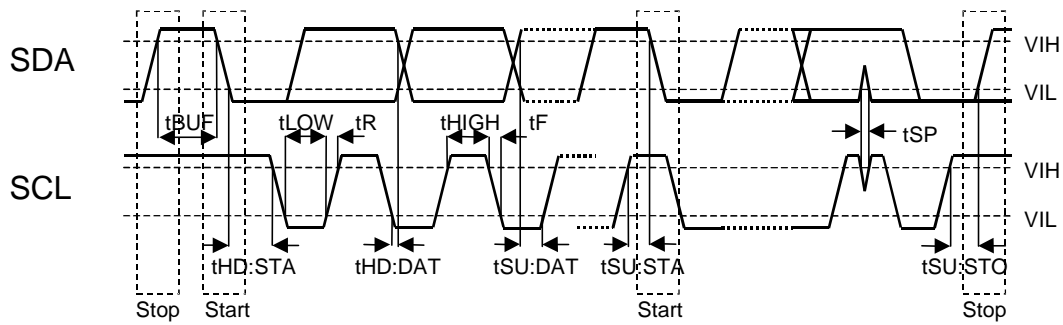

Figure 2. Timing Diagram

OPERATION OVERVIEW

■ Function Overview

The AK4187 consists of the following blocks:

- 12-bit Successive Approximation Register(SAR) A/D converter
- 4-wire resistive touch screen controller interface with dual touch detection(6-wire connection)
- Continuous A/D converter
- Calculator
- Internal Clock Generator for SAR A/D converter
- I²C I/F

Figure 3 shows the system connection diagram for the AK4187. Normally, a touch screen controller is connected to 4-wire resistive touch screen by 4 wires, but the AK4187 is connected to the screen by 6 wires that add the RXP and RYP pin connections for dual touch gestures.

AK4187 pin	Connection between the AK4187 and Touch Panel
XP	This pin is directly connected to X+ metal contact of touch panel.
XN	This pin is connected to X- metal contact of touch panel via resistor R4. For dual touch detection.
YP	This pin is directly connected to Y+ metal contact of touch panel.
YN	This pin is connected to Y- metal contact of touch panel via resistor R3. For dual touch detection.
RXP	This pin is connected to X+ metal contacted of touch panel via resistor R2.
RYP	This pin is connected to Y+ metal contacted of touch panel via resistor R1.

- Note 10. The RXP pin and the RYP pin are additional pins for dual touch operation.
 Note 11. The resistance of R1 should be 75% value of the touch panel resistance in Y axis direction.
 Note 12. The resistance of R2 should be 75% value of the touch panel resistance in X axis direction.
 Note 13. The resistance of R3 should be quarter value of the touch panel resistance in Y axis direction.
 Note 14. The resistance of R4 should be quarter value of the touch panel resistance in X axis direction.
 Note 15. ±20% tolerance of resistance is allowed for R1~R4

Table 1. The Connection between the AK4187 and Touch Panel

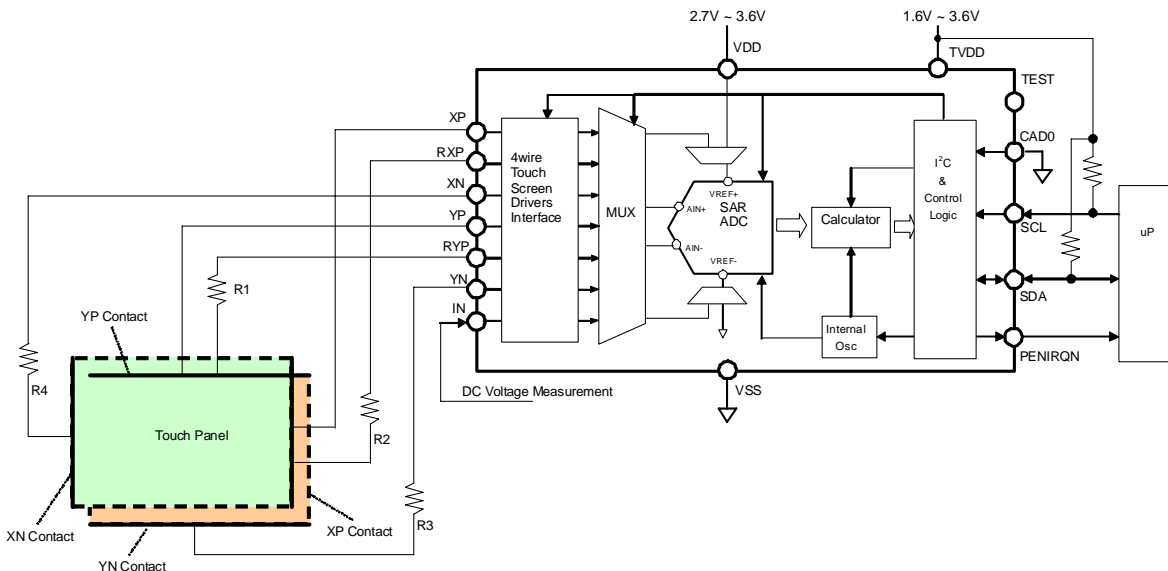

Note 16. This figure is the connection diagram when the CAD0 pin= "L". In case of the CAD0 pin= "H", the CAD0 pin must be connected to TVDD.

Figure 3. The Connection Diagram of AK4187

■ A/D Converter for Touch Screen

The AK4187 integrates a 12bit successive approximation register (SAR) A/D converter for position measurement and auxiliary input. The architecture is based on capacitive redistribution algorithm, and an internal capacitor array functions as a sample/hold (S/H) circuit.

The SAR A/D converter output is a straight binary format as shown below:

Input Voltage	Output Code
$(\Delta VREF - 1.5LSB) \sim \Delta VREF$	FFFH
$(\Delta VREF - 2.5LSB) \sim (\Delta VREF - 1.5LSB)$	FFE H
-----	-----
0.5LSB \sim 1.5LSB	001H
0 \sim 0.5LSB	000H

$\Delta VREF: (VREF+) - (VREF-)$

Table 2. Output Code

The f_{OSC} clock of an internal oscillator is used for A/D conversion. The full scale ($\Delta VREF$) of the A/D converter depends on the input mode. Position and pen pressure are measured in differential mode, and IN is measured in single-ended mode. The AK4187 is controlled by 8bit serial command. A/D conversion result is 12bit data output on the SDA pin.

■ Single Touch Process

The analog input channel is automatically selected. When position detection (X-axis and Y-axis) and pen pressure are selected as analog inputs in differential mode, the full scale ($\Delta VREF$) is the voltage difference between the non-inverting terminal and the inverting terminal of the measured axis (e.g. X-axis measurement: (XP) - (XN)). Analog input to A/D converters (ΔAIN) is the voltage difference between the non-inverting terminal of the non-measured axis and the inverting terminal of the measured axis. At single-ended mode, the full scale of A/D converter ($\Delta VREF$) is the voltage difference between the VDD and the VSS. The analog input of A/D converter (ΔAIN) is the voltage difference between the selected channel (IN) and the VSS.

If the source of analog input is high impedance, longer tracking time is required. Then A/D conversion should be started.

Channel Selection	Status of Driver Switch		ADC input (ΔAIN)		Reference Voltage ($\Delta VREF$)		Ref. Mode
	X-Driver	Y-Driver	AIN+	AIN-	VREF+	VREF-	
AIN Measure	OFF	OFF	IN	GND	VREF	GND	SER
X-axis Measure (Xp1)	ON	OFF	YP	XN	XP	XN	DFR
Y-axis Measure (Yp1)	OFF	ON	XP	YN	YP	YN	DFR
Z1 Measure (Pressure)	XN-ON	YP-ON	XP	XN	YP	XN	DFR
Z2 Measure (Pressure)	XN-ON	YP-ON	YN	XN	YP	XN	DFR

Table 3. Measurement Mode

■ Position Detection of Touch Screen

The position on the touch screen is detected by taking the voltage of one axis when the voltage is supplied between the two terminals of another axis.

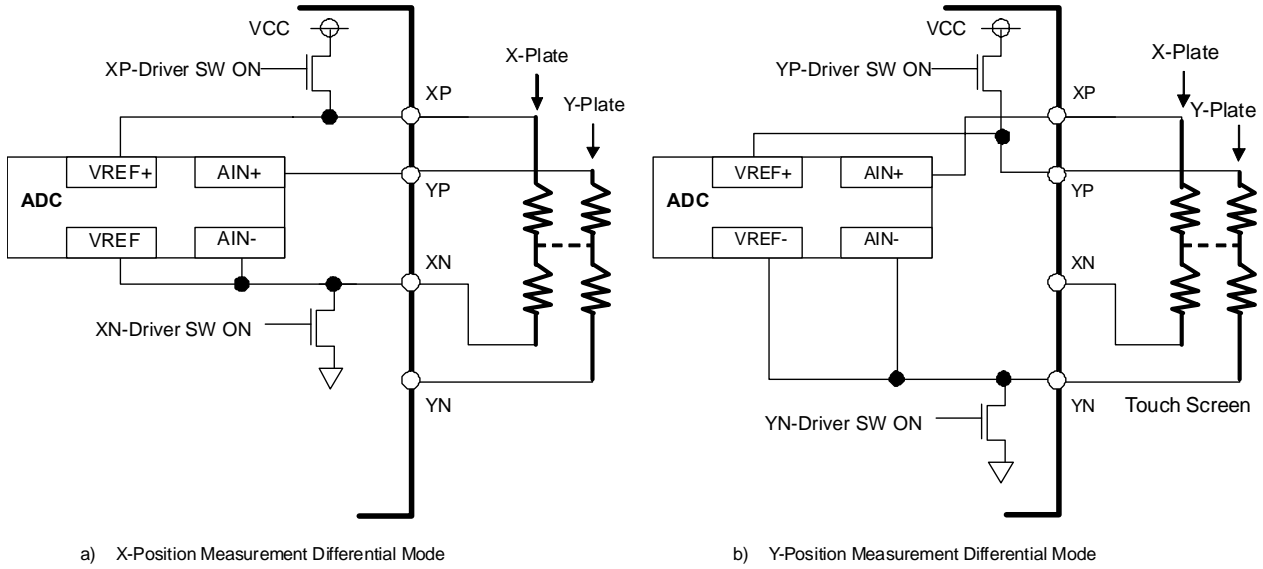

The X-plate and Y-plate are connected on the dotted line when the panel is touched.

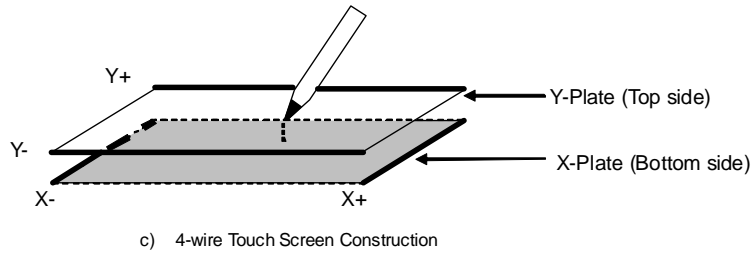

Figure 4. Axis Measurements for 4-wire Touch Screen

■ Pen Pressure Measurement

The touch screen pen pressure can be derived from the measurement of the contact resistor between two plates. The contact resistance depends on the size of the depressed area and the pressure. The area of the spot is proportional to the contact resistance.

This resistance (R_{touch}) can be calculated using two different methods. The first method is that when the total resistance of the X-plate sheet is already known. The resistance, R_{touch}, is calculated from the results of three conversions, X-position, Z1-position, and Z2-position, and then using following formula:

$$R_{TOUCH} = R_{X\text{-plate}} \cdot \frac{X_{\text{Position}}}{4096} \left(\frac{Z_2}{Z_1} - 1 \right)$$

The second method is that when both the resistances of the X-plate and Y-plate are known. The resistance, R_{touch}, is calculated from the results of three conversions, X-position, Y-position, and Z1-position, and then using the following formula:

$$R_{TOUCH} = \frac{R_{X\text{-plate}} \cdot X_{\text{Position}}}{4096} \left(\frac{4096}{Z_1} - 1 \right) - R_{Y\text{-plate}} \cdot \left(1 - \frac{Y_{\text{Position}}}{4096} \right)$$

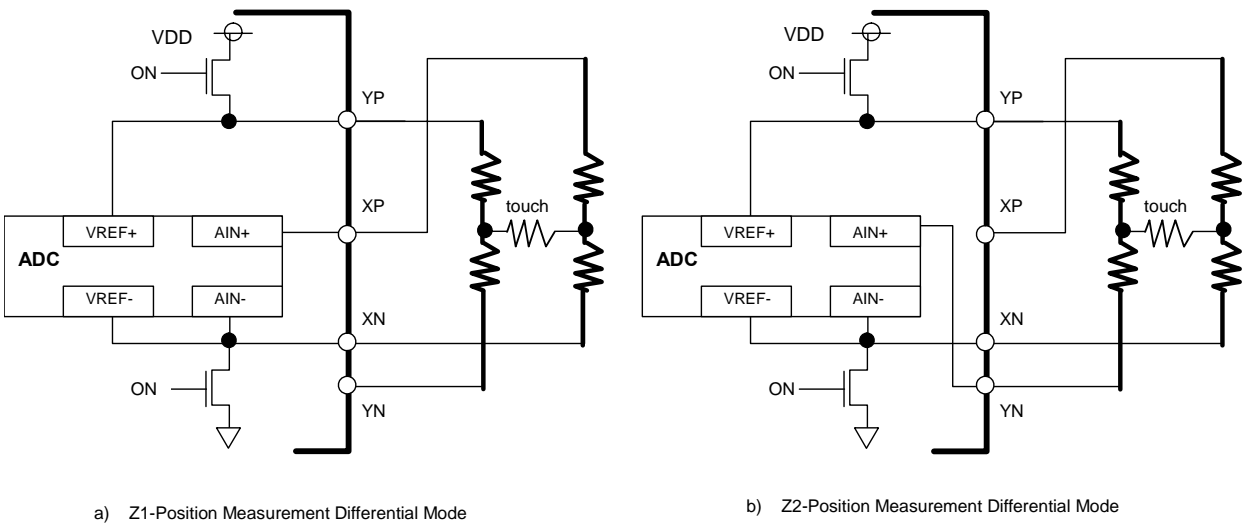

Figure 5. Pen Pressure Measurements

■ Pen Interrupt

The AK4187 has pen interrupt function to detect pen touches. (Figure 6). The YN pin is connected to VSS at the PEN interrupt enabled state. The XP pin is pulled up via an internal resistor (R_{IRQ} : typ.50k Ω). The PENIRQN pin is connected to the XP pin internally. If the touch plate is pressed by a pen, the current flows via <VDD> - <Ri> - <X+> - <Y-> (4-wire). The resistance of the plate is generally 1k Ω or less, PENIRQN is forced to “L” level. If the pen is released, the PENIRQN pin returns “H” level because two plates are disconnected, and the current does not flow via two plates.

During Sequence measurement or calculations, the pen interrupt function is disabled, and the PENIRQN pin is operated as “Busy” signal. While in sleep mode, the pen interrupt function is disabled, and the PENIRQN pin is “H” or “Hi-z”. (Refer to Table 10. Sleep Mode)

It is recommended that the micro controller masks the pseudo-interrupts while the sequence measurement is busy.

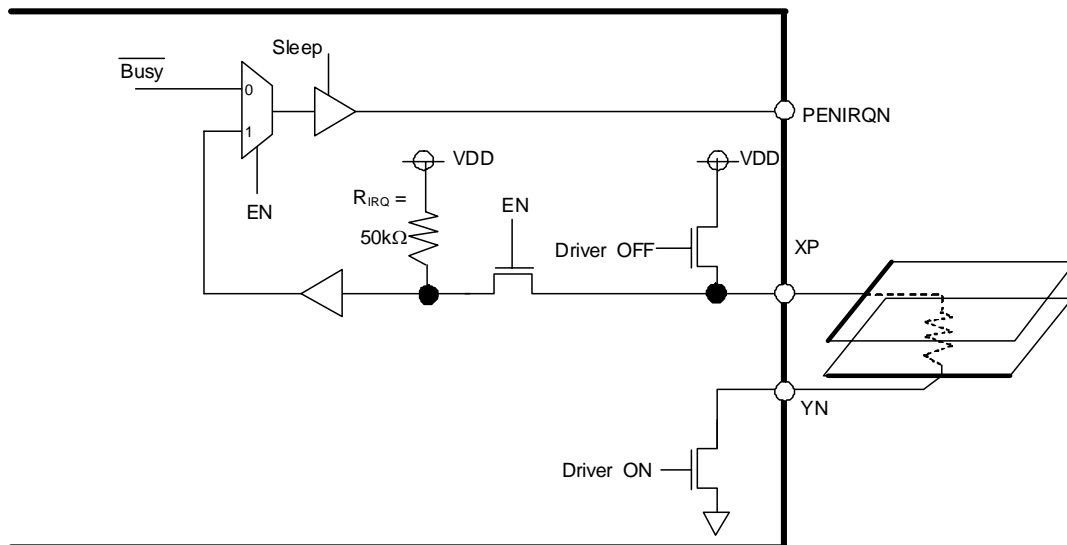

Figure 6. PENIRQN Function Block Diagram

■ Dual Touch Process

The AK4187 has the function for dual touch processing. The AK4187 registers the center location of dual touch and the parameter that related to dual touch distance when SEQM3-0bits is set to “1010”.

Detected Value		Symbol	Register	
			Address	bit
X center location of dual touch (12bit)	Upper 8bit	Xp21	11H	D7-D0
	Lower 4bit		12H	D7-D4
Y center location of dual touch (12bit)	Upper 8bit	Yp21	13H	D7-D0
	Lower 4bit		14H	D7-D4
Parameter that related to dual touch X distance (12bit)	Upper 8bit	XDual	15H	D7-D0
	Lower 4bit		16H	D7-D4
Parameter that related to dual touch Y distance (12bit)	Upper 8bit	YDual	17H	D7-D0
	Lower 4bit		18H	D7-D4
Status bit of insufficient pressure in dual touch 0: Sufficient pressure 1: Insufficient pressure		TPRND	10H	D5
Status bit for insufficient pressure in single touch 0: Sufficient pressure 1: Insufficient pressure		TPRNS	10H	D4
Status bit of dual touch direction. The sign bit of Δy , if $\Delta x \geq 0$. $\Delta x = (x_2 - x_1)$, $\Delta y = (y_2 - y_1)$ 0: $\Delta y < 0$ 1: $\Delta y \geq 0$		DSNG	10H	D3
Dual touch detection bit 0: Single Touch Detection 1: Dual Touch Detection		Dual	10H	D2

Table 4. Output Data of Dual Touch Processing

■ Digital I/F

The AK4187 is controlled by a microprocessor via the I²C bus, and it supports both standard mode (100kHz) and fast mode (400kHz). Note that the AK4187 operates in those two modes and does not support a High speed mode I²C-bus system (3.4MHz). The AK4187 can operate as a slave device on the I²C bus network. The digital I/O of AK4187 operates off of supply voltage down to 1.6V in order to connect a low voltage microprocessor.

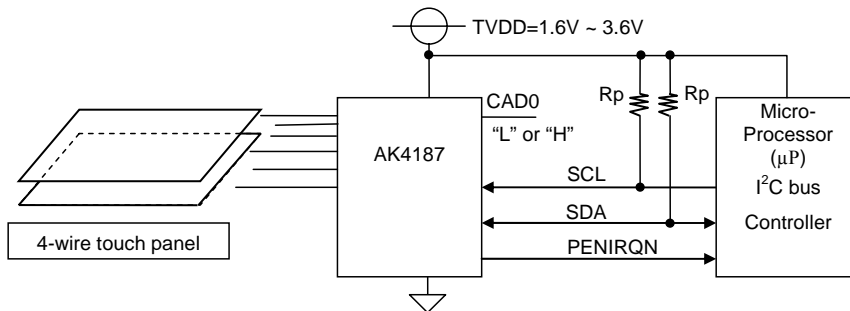

Figure 7. Digital I/F

1. WRITE Operations

Figure 8 shows the data transfer sequence for the I²C-bus mode. All commands are preceded by START condition. A HIGH to LOW transition on the SDA line while SCL is HIGH indicates START condition (Figure 12). After the START condition, a slave address is sent. This address is 6 bits long followed by the eighth bit that is a data direction bit (R/W). The most significant six bits of the slave address are fixed as “100100”. The next bit is CAD0 (device address bit). This bit identifies the specific device on the bus. The hard-wired input pin (CAD0 pin) set this device address bit (Figure 8). If the slave address matches that of the AK4187, the AK4187 generates an acknowledge and the operation is executed. The master must generate the acknowledge-related clock pulse and release the SDA line (HIGH) during the acknowledge clock pulse (Figure 13). R/W bit value of “1” indicates that the read operation is to be executed. “0” indicates that the write operation is to be executed.

The second byte consists of the control register address of the AK4187. The format is MSB first, and those most significant two bits are fixed to zeros (Figure 10). The data after the second byte contains control data. The format is MSB first, 8bits (Figure 11). The AK4187 generates an acknowledge after each byte is received. A data transfer is always terminated by STOP condition generated by the master. A LOW to HIGH transition on the SDA line while SCL is HIGH defines STOP condition (Figure 12).

The AK4187 can perform more than one byte write operation per sequence. After receipt of the third byte the AK4187 generates an acknowledge and awaits the next data. The master can transmit more than one byte instead of terminating the write cycle after the first data byte is transferred. After receiving each data packet the internal 6-bit address counter is incremented by one, and the next data is automatically taken into the next address. If the address exceeds “26H” prior to generating stop condition, the address counter will “roll over” to 00H and the previous data will be overwritten.

The data on the SDA line must remain stable during the HIGH period of the clock. HIGH or LOW state of the data line can only change when the clock signal on the SCL line is LOW (Figure 14) except for the START and STOP conditions.

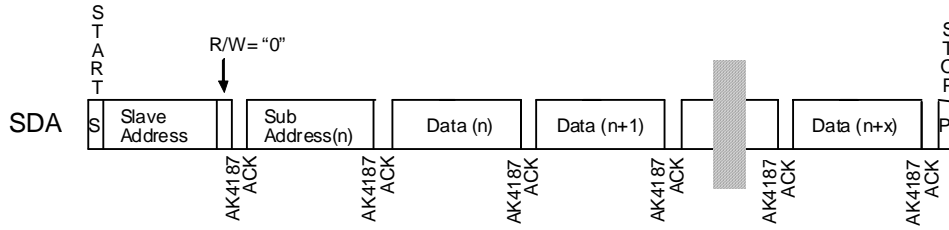
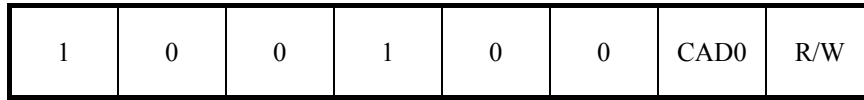

Figure 8. Data Transfer Sequence at the I²C-Bus Mode



(This CAD0 should match with CAD0 pin.)

Figure 9. The First Byte

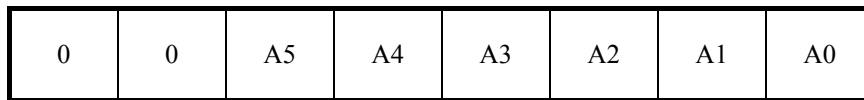

Figure 10. The Second Byte

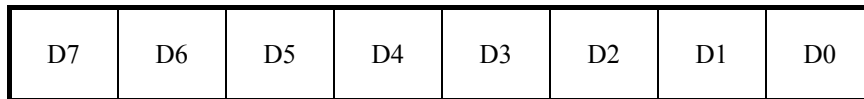

Figure 11. Byte Structure after The Second Byte

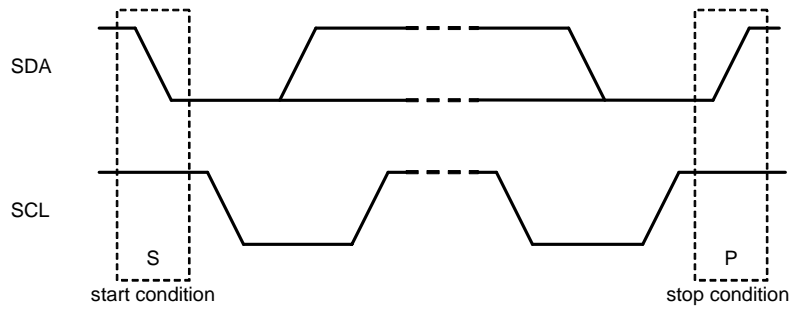

Figure 12. START and STOP Conditions

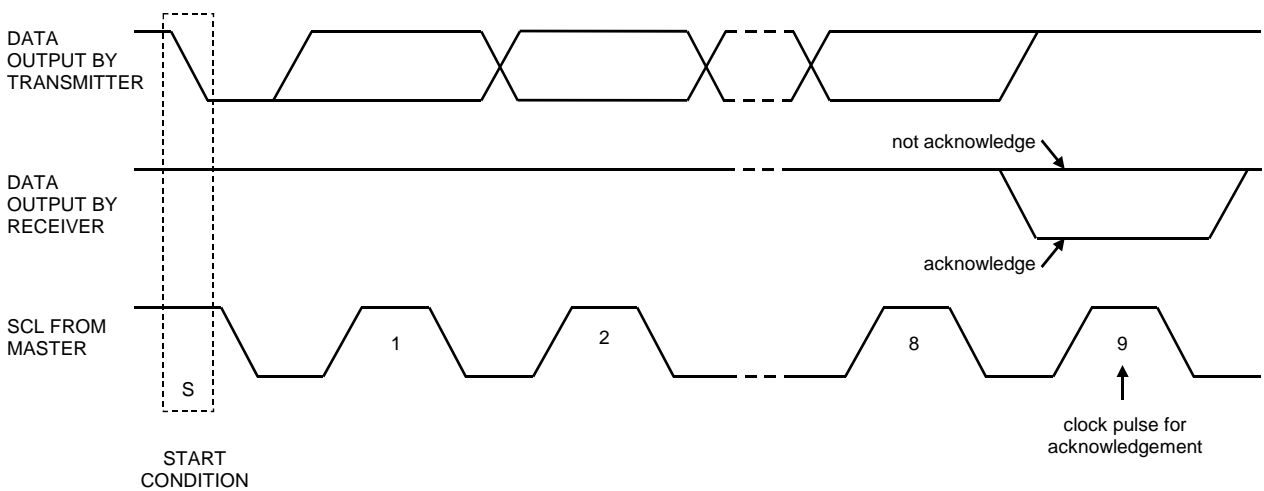

Figure 13. Acknowledge on the I²C-Bus

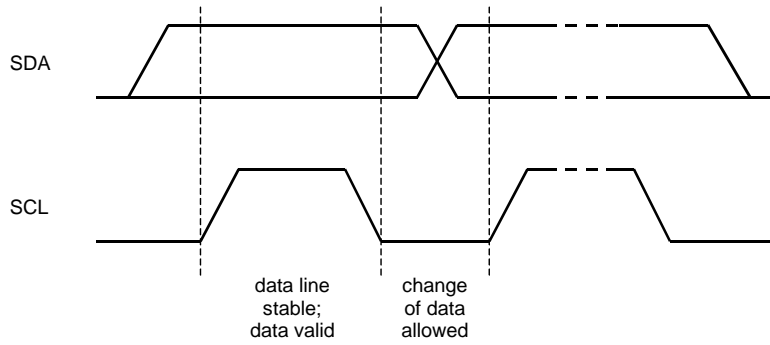

Figure 14. Bit Transfer on the I²C-Bus

2. READ Operations

Set the R/W bit = “1” for the READ operation of the AK4187.

After transmission of data, the master can read the next address’s data by generating an acknowledge instead of terminating the write cycle after the receipt of the first data word. After receiving each data packet the internal 6-bit address counter is incremented by one, and the next data is automatically taken into the next address. If the address exceeds “26H” prior to generating stop condition, the address counter will “roll over” to 00H and the data of 00H will be read out. The register read operation allows the master to access any memory location at random. Prior to issuing the slave address with the R/W bit “1”, the master must first perform a “dummy” write operation. The master issues a start request, a slave address (R/W bit = “0”) and then the register address to read. After the register address is acknowledged, the master immediately reissues the start request and the slave address with the R/W bit “1”. The AK4187 then generates an acknowledge, 1 byte of data, and increments the internal address counter by 1. If the master does not generate an acknowledge but generates a stop condition instead, the AK4187 ceases transmission. A/D conversion data in sequence mode can be read when the data is available.

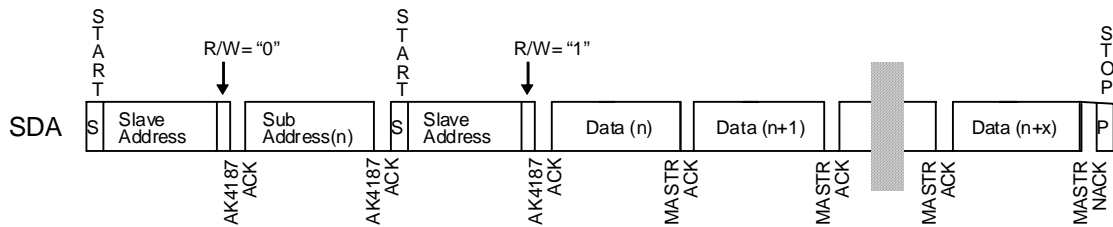

Figure 15. Register Address Read

■ Register Map

Addr	Register Name	D7	D6	D5	D4	D3	D2	D1	D0	Stat
00H	System Reset	0	0	0	0	0	0	0	SRST	W
01H	Setup Command	0	0	SLEEP1	SLEEP0	0	0	0	0	R/W
02H	Sequence Command	SEQM3	SEQM2	SEQM1	SEQM0	COUNT	INTERVAL2	INTERVAL1	INTERVAL0	R/W
03H	Dual Touch Measure Parameter 1	0	RCMP2	RCMP1	RCMP0	0	INTERVAL2	INTERVAL1	INTERVAL0	R/W
04H	Touch Pressure1	THXZS7	THXZS6	THXZS5	THXZS4	THXZS3	THXZS2	THXZS1	THXZS0	R/W
05H	Touch Pressure2	THXZD7	THXZD6	THXZD5	THXZD4	THXZD3	THXZD2	THXZD1	THXZD0	R/W
06H	Dual Touch Judgment1	THDXY7	THDXY6	THDXY5	THDXY4	THDXY3	THDXY2	THDXY1	THDXY0	R/W
07H	Dual Touch Judgment2	SRCMP7	SRCMP6	SRCMP5	SRCMP4	SRCMP3	SRCMP2	SRCMP1	SRCMP0	R/W
08H	Dual Touch Parameter1	BX7	BX6	BX5	BX4	BX3	BX2	BX1	BX0	R/W
09H	Dual Touch Parameter2	CX7	CX6	CX5	CX4	CX3	CX2	CX1	CX0	R/W
0AH	Dual Touch Parameter3	BY7	BY6	BY5	BY4	BY3	BY2	BY1	BY0	R/W
0BH	Dual Touch Parameter4	CY7	CY6	CY5	CY4	CY3	CY2	CY1	CY0	R/W
0CH	Dual Touch Measure Parameter 2	RSTRC	DXYC	THDUAL5	THDUAL4	THDUAL3	THDUAL2	THDUAL1	THDUAL0	R/W
0DH-0FH	Reserved									
10H	Status	0	0	TPRND	TPRNS	DSNG	DUAL	SEQDVAL	SEQBSY	R
11H	Sequence Data 1H	D1T11	D1T10	D1T9	D1T8	D1T7	D1T6	D1T5	D1T4	R
12H	Sequence Data 1L	D1T3	D1T2	D1T1	D1T0	0	0	0	0	R
13H	Sequence Data 2H	D2T11	D2T10	D2T9	D2T8	D2T7	D2T6	D2T5	D2T4	R
14H	Sequence Data 2L	D2T3	D2T2	D2T1	D2T0	0	0	0	0	R
15H	Sequence Data 3H	D3T11	D3T10	D3T9	D3T8	D3T7	D3T6	D3T5	D3T4	R
16H	Sequence Data 3L	D3T3	D3T2	D3T1	D3T0	0	0	0	0	R
17H	Sequence Data 4H	D4T11	D4T10	D4T9	D4T8	D4T7	D4T6	D4T5	D4T4	R
18H	Sequence Data 4L	D4T3	D4T2	D4T1	D4T0	0	0	0	0	R
19H-1FH	Reserved									
20H	R_XT0	RXTZ11	RXTZ10	RXTZ9	RXTZ8	RXTZ7	RXTZ6	RXTZ5	RXTZ4	R
21H		RXTZ3	RXTZ2	RXTZ1	RXTZ0	0	0	0	0	R
22H	R_YT0	RYZT11	RYZT10	RYZT9	RYZT8	RYZT7	RYZT6	RYZT5	RYZT4	R
23H		RXTZ3	RYZT2	RYZT1	RYZT0	0	0	0	0	R
24H	DXYS	DXYS 7	DXYS 6	DXYS 5	DXYS 4	DXYS 3	DXYS 2	DXYS 1	DXYS 0	R
25H	XZ21	0	0	XZ9	XZ8	XZ7	XZ6	XZ5	XZ4	R
26H		XZ3	XZ2	XZ1	XZ0	0	0	0	0	R

Table 5. AK4187 Register Map

Note 17. The bits defined as 0 must contain a “0” value.

Note 18. Reading the reserved address (0DH~0FH, 19H~1FH) is not possible.

■ Register Detail

1. System Reset Configuration

Addr	Register Name	D7	D6	D5	D4	D3	D2	D1	D0
00H	System Reset	0	0	0	0	0	0	0	SRST

Table 6. System Reset Register Format

Bits	Name	Description
D7-D1	Reserved	Must write "0"
D0	SRST	System Reset Register System reset is executed by writing "1" in this register. The internal register is initialized by system reset, and the AK4187 is set to the touch detection waiting (stand-by state). A sequential measurement will be forced to stop by this system reset. In this case, all data are cleared.

Table 7. System Reset Description

2. Setup Command Configuration

Addr	Register Name	D7	D6	D5	D4	D3	D2	D1	D0
01H	Setup Command	0	0	SLEEP1	SLEEP0	0	0	0	0

Table 8. Setup Command Register Format

Bits	Name	Description	Default
D7-D6	Reserved	Must write "0"	
D5-D4	SLEEP1-0	Sleep Command 00: Normal Mode (default) 01: Sleep Mode 1 (PENIRQN disabled and output "H". Touch Panel is open.) 10: Sleep Mode 2 (PENIRQN disabled and open. Touch Panel is open.) 11: Reserved	0x0
D3-D0	Reserved	Must write "0"	

Table 9. Setup Command Description

SLEEP1-0 bits can be written during a sequential measurement.

The AK4187 supports sleep mode that puts the touch panel to open state and disable pen interrupt function, effective for reducing power consumption caused by unnecessary pen touches. Sleep mode is controlled by SLEEP1-0 bits. All touch screen driver switches are powered down in this sleep mode, and it reduces power consumption to the minimum value. The PENIRQN output in this mode is shown below. (Table 10)

The AK4187 returns to normal operation out of sleep mode when the micro-controller writes "00" to SLEEP1-0 bits.

SLEEP1-0	Pen Interrupt Function	Touch Panel Driver	PENIRQN Output
00	Enable	Normal Operation	Pen Interrupt
01	Disable	Open	H
10	Disable	Open	Hi-z
11	N/A	N/A	N/A

(N/A: Not available)

Table 10. Sleep Mode

A/D conversion is available during sleep mode by issuing an ADC executing command (sequential). The AK4187 returns to sleep mode after completing an A/D conversion.

3. Sequence Command Configuration

Addr	Register Name	D7	D6	D5	D4	D3	D2	D1	D0
02H	Sequence Command	SEQM3	SEQM2	SEQM1	SEQM0	COUNT	INTERVAL2	INTERVAL1	INTERVAL0

Table 11. Sequence Command Register Format

The AK4187 starts A/D conversion in sequence mode by setting the SEQM3-0, COUNT, INTERVAL2-0 bits of the register address 02H. The AK4187 makes six or ten measurements by setting the COUNT bit. The results are used to calculate the average value, discarding the minimum and maximum values, and the result sets the data register of sequence mode. If the address 02H is set again during a sequential measurement, this setting is ignored and the AK4187 continues the measurement. The master executes the register read operation to read the measurement data of sequence mode after confirming the PENIRQN pin turns to “H” (Data Available).

Bits	Name	Description	Default
D7-D4	SEQM3-0	Sequence Mode 0000: Xp1 → Yp1 → Z1 → Z2 Scan (default) 0001: Xp1 → Yp1 Scan 0010: Xp1 Scan 0011: Yp1 Scan 0100: Z1 → Z2 Scan 0101: Reserved 0110: A-IN 0111: Reserved 1000 – 1111: Table 13	0x0
D3	COUNT	ADC Conversion count 0: 6 times AD Conversion (default) 1: 10 times AD Conversion	0x0
D2-D0	INTERVAL2-0	Sampling interval times. (Note 19) 000: 0μs (default) 001: 5μs 010: 10μs 011: 20μs 100: 50μs 101: 100μs 110: 200μs 111: 500μs	0x0

Note 19. INTERVAL2-0 bits controls sampling interval times of when measuring by the RXP and RYP pins. External resistor effects can be considered by this setting. ([Table 15](#))

Table 12. Sequence Command Description

SEQM3-0 bits	Function
1000	Dual Touch Initialization. After power up the AK4187, the parameter for dual touch R_XT0 and R_YT0 (Addr0x20-0x23) must be initialized while the PENIRQN pin is “H”.
1001	Dual Touch Calibration. This value must be written when the PENIRQN pin is “H”. DXYS (Addr0x24) is initialized and R_XT0 and R_YT0 are updated by this setting.
1010	Dual Touch Measurement It must be executed when the PENIRQN pin is “L”. The AK4187 measures the dual touch center location and the parameter that related to dual touch distance. If Panel touch is single touch, the single touch location is set to the data register.
1011-1111	Reserved

Table 13. Sequence Mode for Dual Touch

4. Dual Touch Measure Parameter 1

Addr	Register Name	D7	D6	D5	D4	D3	D2	D1	D0
03H	Dual Touch Measure Parameter 1	0	RCMP2	RCMP1	RCMP0	0	INTERV ALR2	INTERV ALR1	INTERV ALR0

Table 14. Dual Touch Measure Parameter 1 Register Format

Bits	Name	Description	Default																		
D7	Reserved	Must write "0"																			
D6-D4	RCMP2-0	XZ21 Correction: $XZ21 = (XZ21 \gg RCMP)$ The inter-electrode resistance and contact resistance are different depending on a touch panel. RCMP must be set in order to maintain $XZ21 < 256$ when dual touch. RCMP value should be less than 4.	0x2																		
D3	Reserved	Must write "0"																			
D2-D0	INTERVALR2-0	Sampling interval time setting. This is the time from driver ON to ADC operation starting when measuring by the RXP and RYP pins. Different times are selectable according to resistor values when connecting a touch panel to the power supply via external resistors.	0x0																		
		<table border="1"> <thead> <tr> <th>INTERVALR2-0</th> <th>Sampling interval times</th> </tr> </thead> <tbody> <tr> <td>000</td> <td>5μs (default)</td> </tr> <tr> <td>001</td> <td>10μs</td> </tr> <tr> <td>010</td> <td>20μs</td> </tr> <tr> <td>011</td> <td>50μs</td> </tr> <tr> <td>100</td> <td>100μs</td> </tr> <tr> <td>101</td> <td>200μs</td> </tr> <tr> <td>110</td> <td>500μs</td> </tr> <tr> <td>111</td> <td>700μs</td> </tr> </tbody> </table>	INTERVALR2-0	Sampling interval times	000	5μs (default)	001	10μs	010	20μs	011	50μs	100	100μs	101	200μs	110	500μs	111	700μs	
INTERVALR2-0	Sampling interval times																				
000	5μs (default)																				
001	10μs																				
010	20μs																				
011	50μs																				
100	100μs																				
101	200μs																				
110	500μs																				
111	700μs																				

Table 15. Dual Touch Measure Parameter 1 Register Description

5. Touch Pressure Parameter

Addr	Register Name	D7	D6	D5	D4	D3	D2	D1	D0
04H	Touch Pressure 1	THXZS7	THXZS6	THXZS5	THXZS4	THXZS3	THXZS2	THXZS1	THXZS0
05H	Touch Pressure 2	THXZD7	THXZD6	THXZD5	THXZD4	THXZD3	THXZD2	THXZD1	THXZD0

Table 16. Touch Pressure Parameter Register Format

Name	Description	Default
THXZS7-0	Single Touch Pressure Judgment When $(XZ21/4) > THXZS$, single touch pressure is insufficient.	0xC0
THXZD7-0	Dual Touch pressure Judgment When $XZ21 > THXZD$, dual touch pressure is insufficient.	0xC0

Table 17. Touch Pressure Parameter Description

6. Dual Touch Judgment

Addr	Register Name	D7	D6	D5	D4	D3	D2	D1	D0
06H	Dual Touch Judgment 1	THDXY7	THDXY6	THDXY5	THDXY4	THDXY3	THDXY2	THDXY1	THDXY0
07H	Dual Touch Judgment 2	SRCMP7	SRCMP6	SRCMP5	SRCMP4	SRCMP3	SRCMP2	SRCMP1	SRCMP0

Table 18. Dual Touch Judgment Register Format

Name	Description	Default
THDXY7-0	Dual Touch pressure Judgment When $DXYS > THDXY$, dual touch is detected.	0x08
SRCMP7-0	DXY Calculation Correction Values DXY offset setting.	0x00

Table 19. Dual Touch Judgment Register Description

7. Dual Touch Parameter

Addr	Register Name	D7	D6	D5	D4	D3	D2	D1	D0
08H	Dual Touch Parameter 1	BX7	BX6	BX5	BX4	BX3	BX2	BX1	BX0
09H	Dual Touch Parameter 2	CX7	CX6	CX5	CX4	CX3	CX2	CX1	CX0
0AH	Dual Touch Parameter 3	BY7	BY6	BY5	BY4	BY3	BY2	BY1	BY0
0BH	Dual Touch Parameter 4	CY7	CY6	CY5	CY4	CY3	CY2	CY1	CY0

Table 20. Dual Touch Parameter Register Format

Name	Description	Default
BX7-0	XDual Calculation Constant.	0x02
CB7-0	XDual Calculation Constant.	0x40
BY7-0	YDual Calculation Constant.	0x02
CY7-0	YDual Calculation Constant	0x40

Table 21. Dual Touch Parameter Register Description

8. Dual Touch Measure Parameter 2

Addr	Register Name	D7	D6	D5	D4	D3	D2	D1	D0
0CH	Dual Touch Measure Parameter 2	RSTRC	DXYC	THDUAL5	THDUAL4	THDUAL3	THDUAL2	THDUAL1	THDUAL0

Table 22. Dual Touch Measure Parameter 2 Format

Bits	Name	Description	Default
D7	RSTRC	R_XT0 and R_YT0 update control when SEQM3-0 bits = "1001" (Dual Touch Calibration) 0: Not Update 1: Update	0x1
D6	DXYC	DXYC bit = "1": $DXTS = (DXYS + DXY) / 2$ DXYC bit = "0": $DXYS = DXY$	0x1
D5-D0	THDUAL5-0	Single Touch Pressure Judgment When $XDual \leq THDUAL$ and $YDual \leq THDUAL$, single touch is detected.	0x00

Table 23. Dual Touch Measure Parameter 2 Description

9. Data Register

The AK4187 starts A/D conversion in sequence mode by setting the SEQM3-0, COUNT, and INTERVAL2-0 bits of the register address 02H. The AK4187 makes six or ten measurements by setting the COUNT bit. The results are used to calculate the average value, discarding the minimum and maximum values, and the result sets the data register of sequence mode. The AK4187 registers data from address 11H in order of SEQM3-0 bits setting. The master can read the ADC data by a register read operation after confirming the PENIRQ pin turns to “H” or register status SEQDVAL bit= “1”(Data Available).

Status register bits; TPRND, TPRNS, DSNG and DUAL bits contain the values when SEQDVAL bit is “1”. These values are cleared to “0” by executing sequential measurement. Therefore, status read should be made when SEQDVAL bit is “1” after sequential measurement.

The data register is Read Clear so that data will be cleared to “0” once it is read. Do not read data during a sequence measurement.

Addr	Register Name	D7	D6	D5	D4	D3	D2	D1	D0
10H	Status	0	0	TPRND	TPRNS	DSNG	DUAL	SEQDVAL	SEQBSY
11H	Data 1H	D1T11	D1T10	D1T9	D1T8	D1T7	D1T6	D1T5	D1T4
12H	Data 1L	D1T3	D1T2	D1T1	D1T0	0	0	0	0
13H	Data 2H	D2T11	D2T10	D2T9	D2T8	D2T7	D2T6	D2T5	D2T4
14H	Data 2L	D2T3	D2T2	D2T1	D2T0	0	0	0	0
15H	Data 3H	D3T11	D3T10	D3T9	D3T8	D3T7	D3T6	D3T5	D3T4
16H	Data 3L	D3T3	D3T2	D3T1	D3T0	0	0	0	0
17H	Data 4H	D4T11	D4T10	D4T9	D4T8	D4T7	D4T6	D4T5	D4T4
18H	Data 4L	D4T3	D4T2	D4T1	D4T0	0	0	0	0

Table 24. Data Register for Sequence Mode (Read Only)

BIT	Name	Description	Default
D7-D6	Reserved		
D5	TPRND	Status bit of insufficient pressure in dual touch 0: Sufficient pressure 1: Insufficient pressure	0
D4	TPRNS	Status bit of insufficient pressure in single touch 0: Sufficient pressure 1: Insufficient pressure	0
D3	DSNG	Status bit for dual touch direction. The sign bit of Δy , if $\Delta x \geq 0$. $\Delta x = (x_2 - x_1)$, $\Delta y = (y_2 - y_1)$ 0: $\Delta y < 0$ 1: $\Delta y \geq 0$	0
D2	DUAL	Dual touch detection bit 0: Single Touch Judgment 1: Dual Touch Judgment (* This bit is even valid when the touch pressure is insufficient.	0
D1	SEQDVAL	Status bit for Sequence data register 0: No Data 1: Data Available	0
D0	SEQBSY	Status bit for the A/D or Calculator 0: Not Busy 1: Sequence Busy	0

Table 25. Status Register Description (Read Only)

Addr	Data	Output Data	Default
11-12H	Data1	First A/D conversion data	0x000
13-14H	Data2	Second A/D conversion data	0x000
15-16H	Data3	Third A/D conversion data	0x000
17-18H	Data4	Forth A/D conversion data	0x000

Table 26. Data Register for Single Touch Command

Addr	Data	Output Data	Default
11-12H	Data1	X Center location for dual touch “Xp21”	0x000
13-14H	Data2	Y Center location for dual touch “Yp21”	0x000
15-16H	Data3	The value that related to dual touch X distance “ Δx ”. (absolute value) Set to “0”, when Single Touch.	0x000
17-18H	Data4	The value that related to dual touch Y distance “ Δy ”. (absolute value) Set to “0”, when Single Touch.	0x000

Table 27. Data Register for Dual Touch Command

10. Dual Touch Monitor Data Register

Addr	Register Name	D7	D6	D5	D4	D3	D2	D1	D0
20H	R_XT0	RXTZ11	RXTZ10	RXTZ9	RXTZ8	RXTZ7	RXTZ6	RXTZ5	RXTZ4
21H		RXTZ3	RXTZ2	RXTZ1	RXTZ0	0	0	0	0
22H	R_YT0	RYTZ11	RYTZ10	RYTZ9	RYTZ8	RYTZ7	RYTZ6	RYTZ5	RYTZ4
23H		RYTZ3	RYTZ2	RYTZ1	RYTZ0	0	0	0	0
24H	DXYS	DXYS7	DXYS6	DXYS5	DXYS4	DXYS3	DXYS2	DXYS1	DXYS0
25H	XZ21	0	0	XZ9	XZ8	XZ7	XZ6	XZ5	XZ4
26H		XZ3	XZ2	XZ1	XZ0	0	0	0	0

Table 28. Dual Touch Monitor Data Format

Name	Description	Default
RXTZ11-0	X axis initial value Parameter This parameter is acquired by the sequence command of SEQM3-0 bits = “1000” or “1001”.	0x800
RYTZ11-0	Y axis initial value Parameter This parameter is acquired by the sequence command of SEQM3-0 bits = “1000” or “1001”.	0x800
DXYS7-0	Two points Detect Parameter	0x00
XZ9-0	Touch Pressure Parameter	0x000

Table 29. Dual Touch Monitor Data Description

Registers in [Table 29](#) are for internal status monitoring.

By reading R_XT0 and R_YT0, dual touch initializing command execution can be confirmed. It is able to check if the initial values are incorrect because of a touch panel contact during the dual touch initializing.

DXYS and XZ21 registers are referred for setting tuning parameters and thresholds.

CONTROL SEQUENCE

■ Power-up Sequence

To fix the I²C interface statement, send a dummy command when first power up. After the dummy command, send a reset command to initialize internal registers.

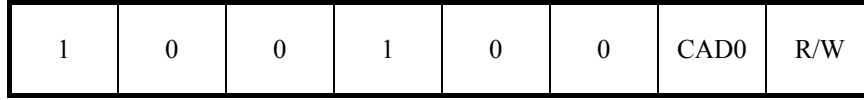

Figure 16. Slave Address Construction (CAD0 is set by a pin)

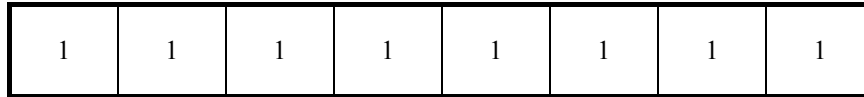

Figure 17. Dummy Address Construction

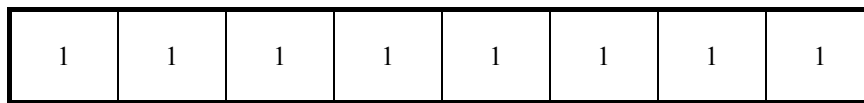

Figure 18. Dummy Command Construction

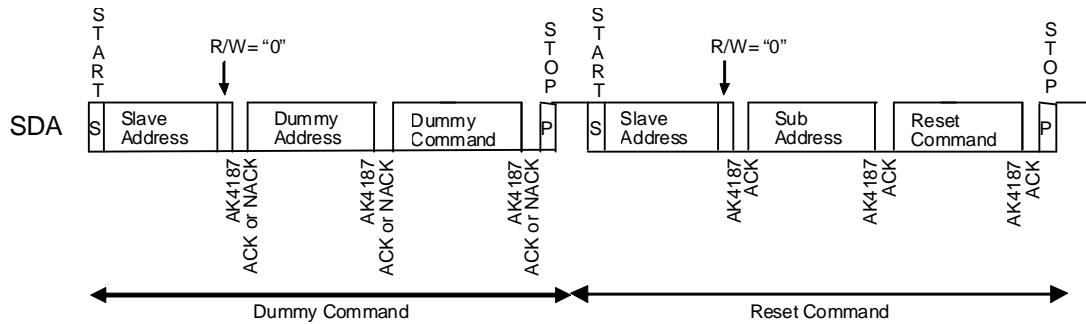

Figure 19. Power-up Sequence

(Note)

After power-up the AK4187, there is a case that the SDA output is hold “L” and dummy command can not be input. This interface lock is released when clock is input to the SCL pin. The I²C interface recognizes “NACK” by “H” input to the SDA pin regardless of the SDA statement. It is initialized in the stop condition after “NACK”.

■ Touch Screen Controller Control Sequence

The AK4187 starts A/D conversion by setting SEQM3-0, COUNT, and INTERVAL2-0 bits of the register address 02H. The pen interrupt function is disabled, the PENIRQN pin is forced to “L” and the internal oscillator is powered up automatically by this sequence command. The AK4187 makes six or ten measurements by setting the COUNT bit. The results are used to calculate the average value, discarding the minimum and maximum value, and dual touch processing is accomplished. The Results sets the data register. When the sequence is finished, the AK4187 sets the PENIRQN pin to “H” and notifies that sequence is ended. After 20us (typ.) is passed from the rising edge of the PENIRQN pin, the internal oscillator is powered down and pen interrupt function is enabled.

The master executes a register read operation to read a measurement data of sequence mode after confirming data availability. The master can confirm data availability by PENIRQN↑ or SEQDVAL bit = “1”.

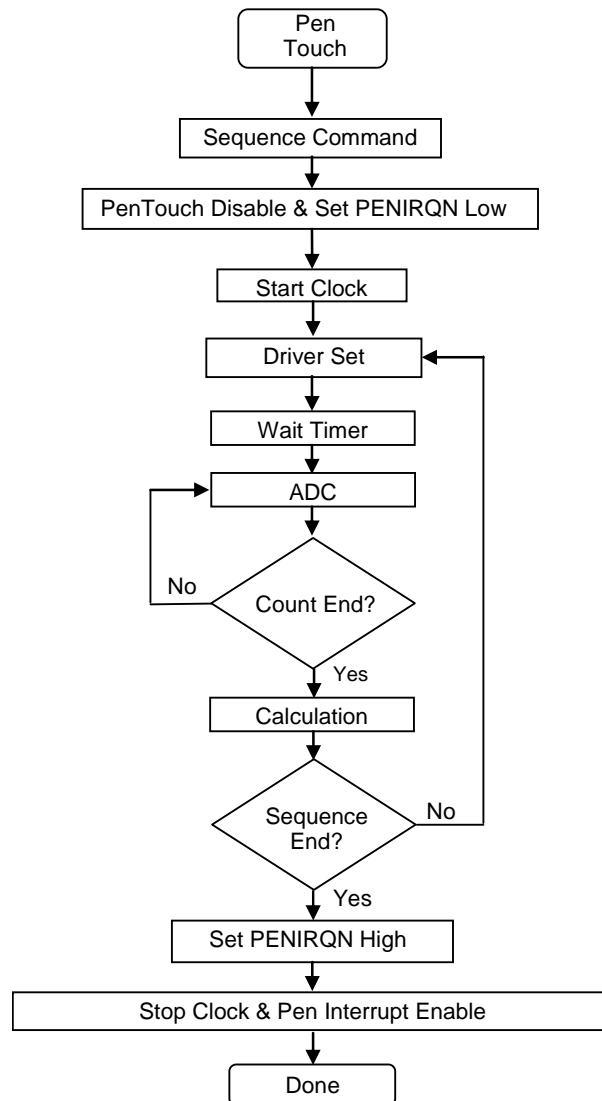

(*) The diamond shape in the flowchart is branch condition. “Yes” is down direction, and “NO” is cross direction
 Figure 20. Sequence Measurement Control Flowchart

This sequence data can be read in register read operation one by one (Address 10H or 11H). Prior to issuing the slave address with the R/W bit “1”, the master must first perform a “dummy” write operation. The master issues start request, a slave address (R/W bit = “0”) and then the register address to read. After the register address is acknowledged, the master immediately reissues the start request and the slave address with the R/W bit “1”. The AK4187 then generates an acknowledge, 1 byte of ADC data, and increments the internal address counter by 1. If the master does not generate an acknowledge but generates stop condition instead, the AK4187 ceases transmission. The A/D data is cleared after reading all the A/D data.

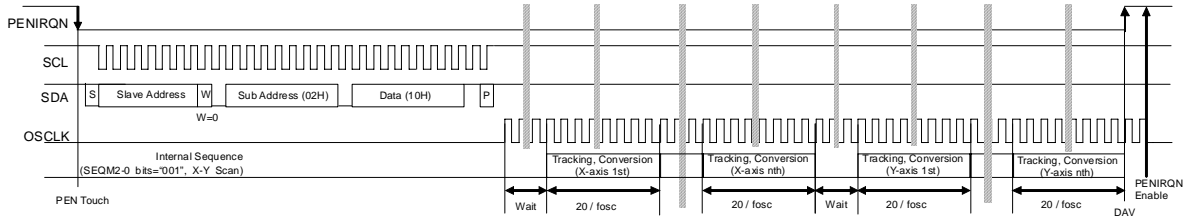

Figure 21. Sequence Measurement Control Sequence (X-Y Scan: SEQM3-0 bits = “0001”) (Sequence Measurement Start→Internal Sequence Processing→Data Available)

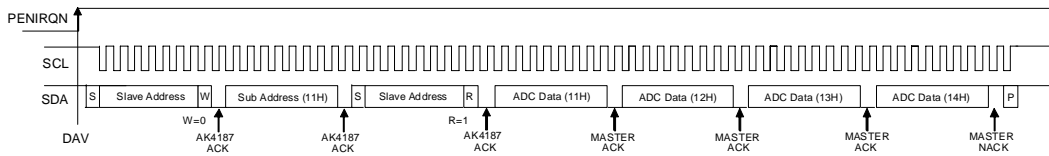

Figure 22. Sequence Measurement Read Operation Sequence (X-Y Scan: SEQM3-0 bits = “0001”) (Data Available→A/D Data Read)

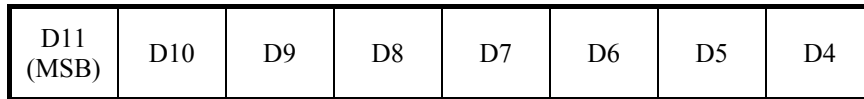

Figure 23. ADC Data (High Byte)

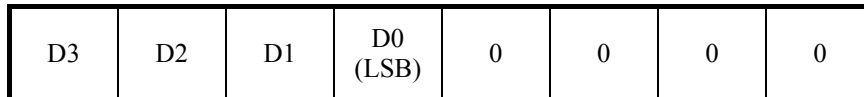

Figure 24. ADC Data (Low Byte)

■ Operation Mode Changes

The AK4187 is set to active mode by a sequence command. Internal OSC, ADC and etc. are powered up, and the AK4187 executes a measurement and a calculation. When the measurement and the calculation are completed, the internal circuit is powered down automatically. Then the AK4187 goes to full power-down mode. In the full power-down mode, the touch detection is controlled by SLEEP1-0 bits.

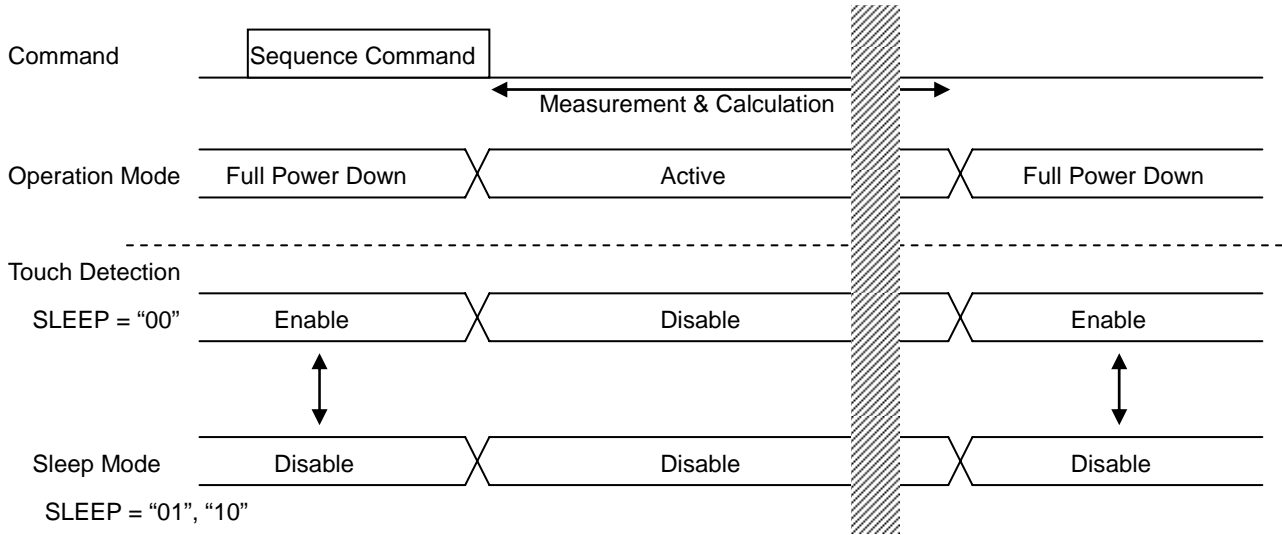

Figure 25. Mode Transition

Operation Mode		Active	Full Power Down		
Register Setting	SLEEP1-0 bits	-	00 Normal Mode	01 Sleep Mode	10 Sleep Mode
Internal Circuit Status	Analog block	Active	Power Down	Power Down	Power Down
	Calculator				
Function Status	Touch Detection	Disable	Enable	Disable	Disable
Pin Status	PENIRQN	L Busy	H/L Touch Status	H	Hi-z

Table 30. Operation Mode

■ uP Process Flowchart

1. Processing Flowchart after System reset

When the master issues a reset command such as in power-up sequence, the AK4187 needs initializing process to get dual touch initial parameters (R_XT0, R_YT0) before detecting dual touch information.

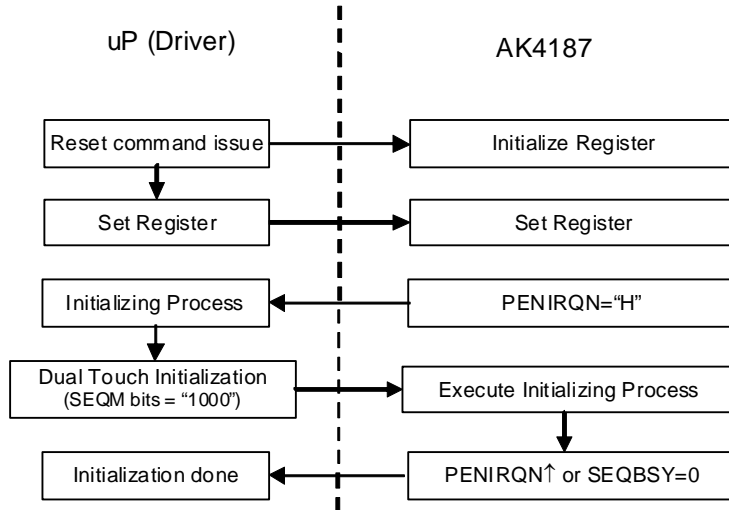

Figure 26. Processing after System Reset

2. Processing Flowchart after Non-Touch

In case of DXYC bit = "1", the AK4187 must be initialized to clear the internal parameter for dual touch (DXYS) when a panel touch is released (PENIRQN↑). R_XT0 and R_YT0 registers are updated when RSTRC bit = "1".

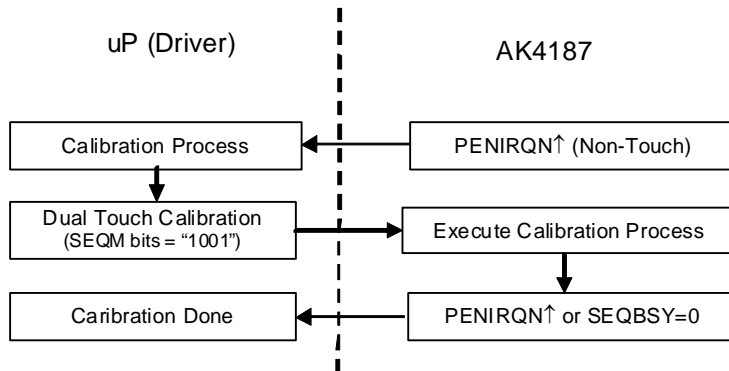

Figure 27. Processing after Non-Touch

3. Sequence Processing Flowchart

The touch arithmetic processing is repeated as shown in Figure 28.

The repeated sequence is in 2ms intervals* (500kHz).

* This time is according to COUNT, INTERVAL and INTERVALR settings.

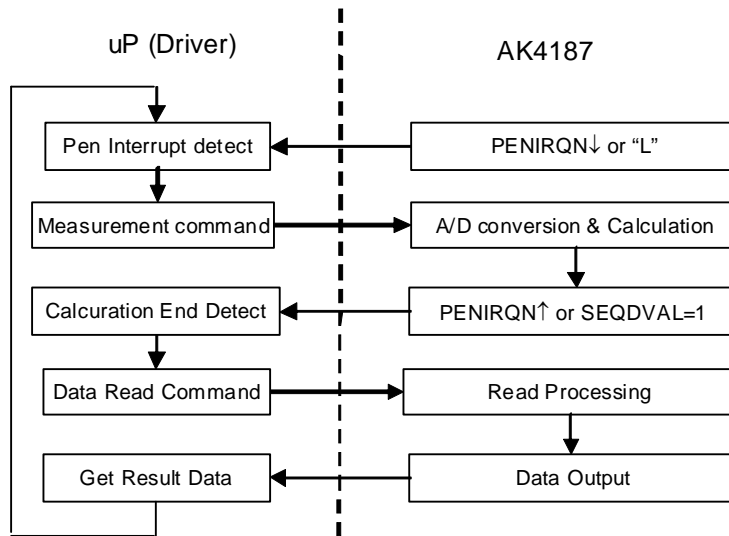

Figure 28. Measuring Sequence Process

SYSTEM DESIGN

Figure 29 and Figure 30 show the system connection diagram for the AK4187. An evaluation board [AKD4187 / AKD4187VN / AKD4187A] demonstrates the optimum layout, power supply arrangements and measurement results.

AK4187EN/AK4187VN

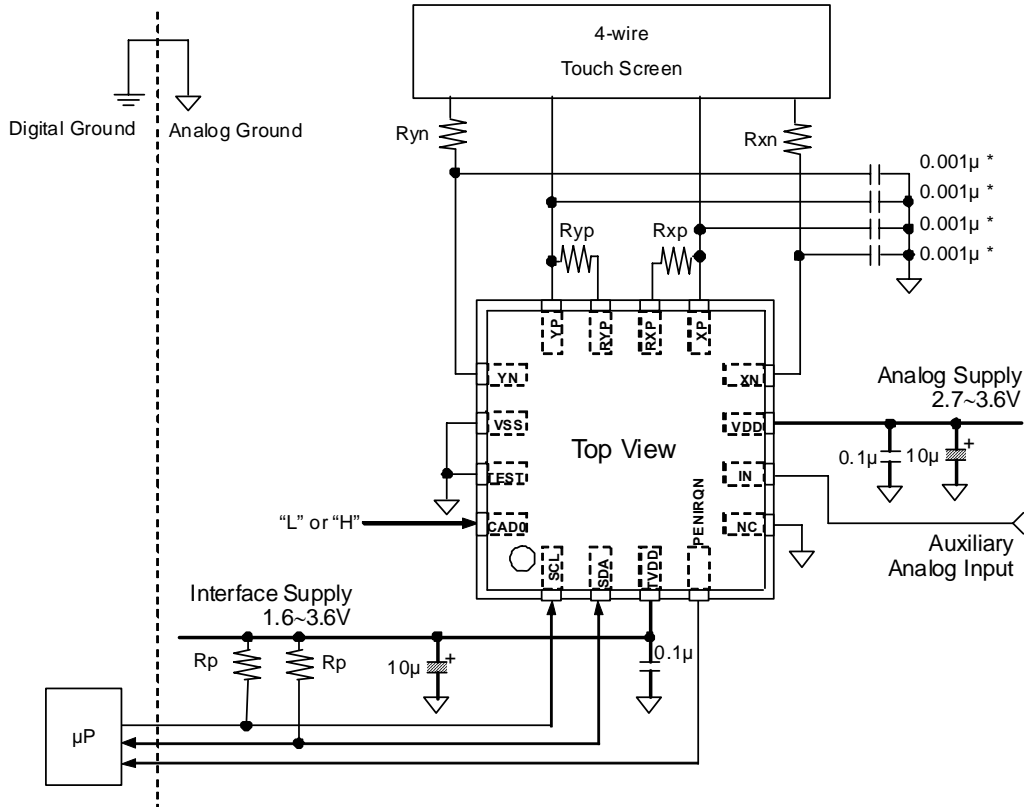

Figure 29. Typical Connection Diagram

Note:

- VSS of the AK4187 should be distributed separately from the ground of external controllers.
- All digital input pins (SCL, SDA, CAD0 pins) must not be allowed to float.
- The resistance of Rxp should be 75% value of the touch panel resistance in X axis direction.
- The resistance of Ryp should be 75% value of the touch panel resistance in Y axis direction.
- The resistance of Rxn should be quarter value of the touch panel resistance in X axis direction.
- The resistance of Ryn should be quarter value of the touch panel resistance in Y axis direction.

AK4187AKT

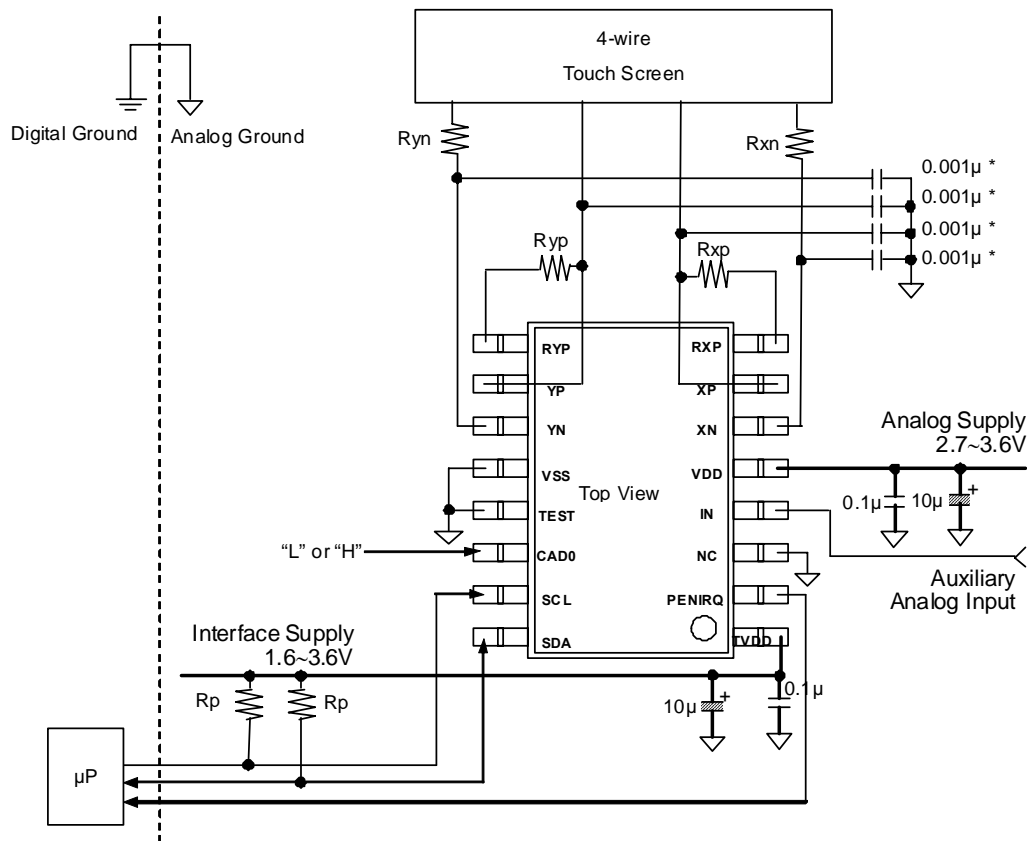

Figure 30. Typical Connection Diagram

Note:

- VSS of the AK4187 should be distributed separately from the ground of external controllers.
- All digital input pins (SCL, SDA, CAD0 pins) must not be allowed to float.
- The resistance of Rxp should be 75% value of the touch panel resistance in X axis direction.
- The resistance of Ryp should be 75% value of the touch panel resistance in Y axis direction.
- The resistance of Rxn should be quarter value of the touch panel resistance in X axis direction.
- The resistance of Ryn should be quarter value of the touch panel resistance in Y axis direction.

1. Grounding and Power Supply Decoupling

The AK4187 requires careful attention to power supply and grounding arrangements. VDD is usually supplied from the system's analog supply. VSS of the AK4187 must be connected to the analog ground plane. System analog ground and digital ground should be connected together near to where the supplies are brought onto the printed circuit board. Decoupling capacitors should be as near to the AK4187 as possible, with the small value ceramic capacitor being the nearest.

2. Analog Inputs

When an EMI source is close to the touch panel analog signal line, EMI noise affects analog characteristics performance. Connect noise canceling capacitors as close as possible to each pin (XP, XN, YP, YN pins) of the AK4187 to avoid this noise.

PACKAGE (AK4187EN / AK4187VN)

16pin QFN (Unit: mm)

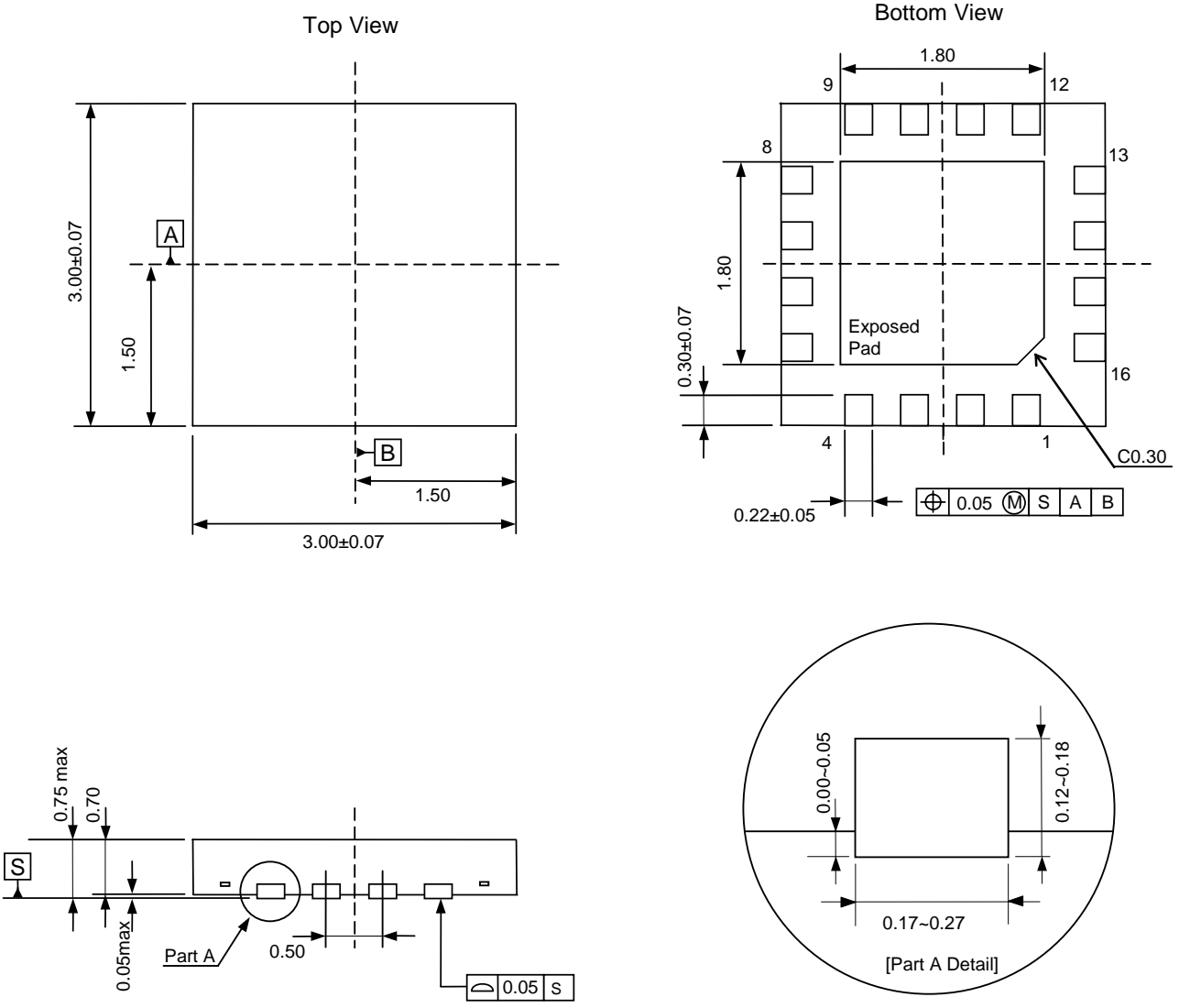

Note: The thermal die pad must be open or connected to the ground.

■ Package & Lead frame material

Package molding compound: Epoxy Resin, Halogen (Br, Cl) Free
 Lead frame material: Cu Alloy
 Lead frame surface treatment: Ni-Pd-Au

PACKAGE (AK4187AKT)

16pin TSSOP (Unit: mm)

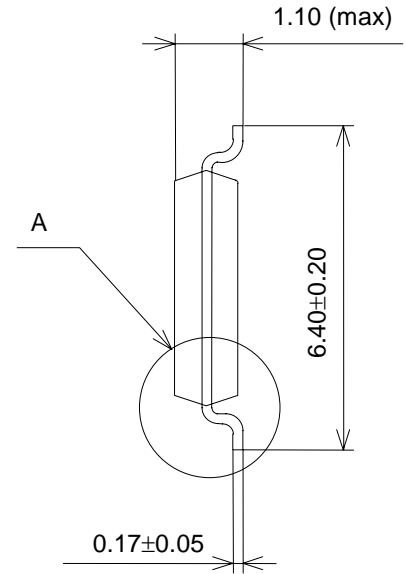
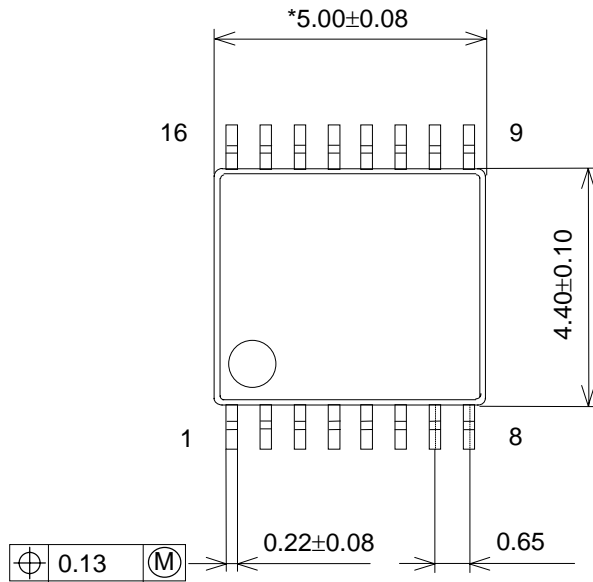

Detail A

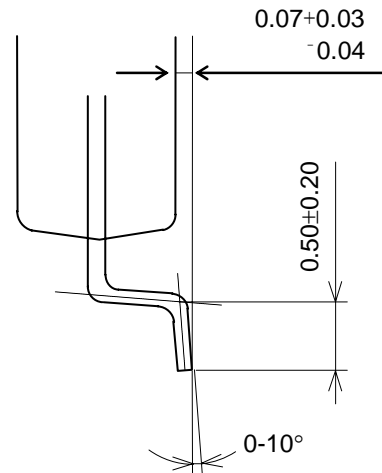
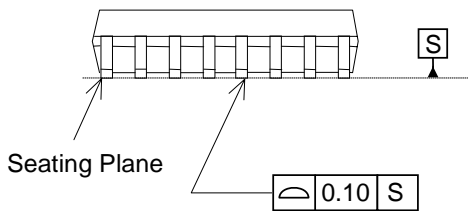

NOTE: Dimension "*" does not include mold flash.

■ Package & Lead frame material

Package molding compound: Epoxy Resin, Halogen (Br, Cl) Free

Lead frame material: Cu Alloy

Lead frame surface treatment: Solder Plate

MARKING (AK4187EN)

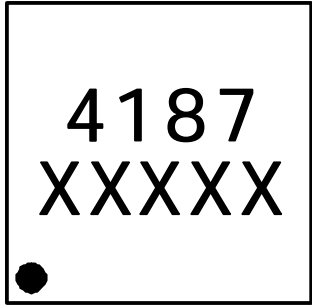

Date Code: XXXXX (5 digits)
Pin #1 indication

MARKING (AK4187VN)

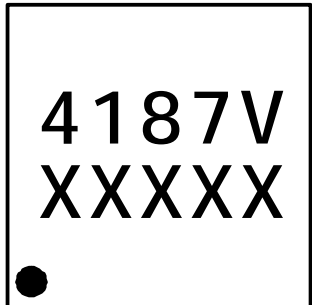

Date Code: XXXXX (5 digits)
Pin #1 indication

MARKING (AK4187AKT)

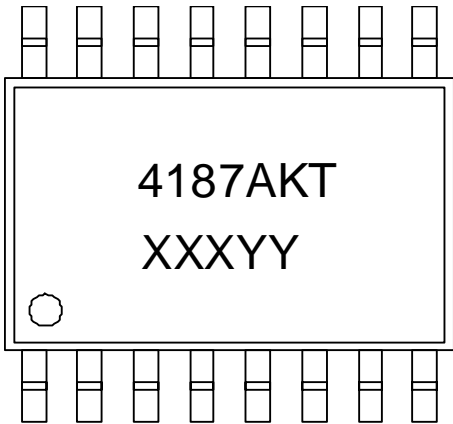

Contents of XXXYY
XXX: Date Code
YY: Internal Control Code

REVISION HISTORY

Date (YY/MM/DD)	Revision	Reason	Page	Contents
10/12/07	00	First Edition		
11/10/17	01	Error Correction	1	Correction of Frequency in Low Power Consumption 450kHz → 450Hz
			6	Correction of "Symbol" THR:STA → tHD:STA THR:DAT → tHD:DAT
11/12/20	02	Product Addition		AK4187VN (for automotive) was added. AK4187AKT (for automotive) was added.
		Error Correction	8	Correction of External Resistor Description 75% value as the touch panel resistance → 75% value of the touch panel resistance
		Description Addition	28	Operation Mode Changes were added.
13/01/16	03	Error Correction	13, 23	Correction of "DSNG" condition 0 : $\Delta y \geq 0 \rightarrow \Delta y < 0$ 1 : $\Delta y < 0 \rightarrow \Delta y \geq 0$

IMPORTANT NOTICE

- These products and their specifications are subject to change without notice.
When you consider any use or application of these products, please make inquiries the sales office of Asahi Kasei Microdevices Corporation (AKM) or authorized distributors as to current status of the products.
- Descriptions of external circuits, application circuits, software and other related information contained in this document are provided only to illustrate the operation and application examples of the semiconductor products. You are fully responsible for the incorporation of these external circuits, application circuits, software and other related information in the design of your equipments. AKM assumes no responsibility for any losses incurred by you or third parties arising from the use of these information herein. AKM assumes no liability for infringement of any patent, intellectual property, or other rights in the application or use of such information contained herein.
- Any export of these products, or devices or systems containing them, may require an export license or other official approval under the law and regulations of the country of export pertaining to customs and tariffs, currency exchange, or strategic materials.
- AKM products are neither intended nor authorized for use as critical components^{Note1)} in any safety, life support, or other hazard related device or system^{Note2)}, and AKM assumes no responsibility for such use, except for the use approved with the express written consent by Representative Director of AKM. As used here:
 - Note1) A critical component is one whose failure to function or perform may reasonably be expected to result, whether directly or indirectly, in the loss of the safety or effectiveness of the device or system containing it, and which must therefore meet very high standards of performance and reliability.
 - Note2) A hazard related device or system is one designed or intended for life support or maintenance of safety or for applications in medicine, aerospace, nuclear energy, or other fields, in which its failure to function or perform may reasonably be expected to result in loss of life or in significant injury or damage to person or property.
- It is the responsibility of the buyer or distributor of AKM products, who distributes, disposes of, or otherwise places the product with a third party, to notify such third party in advance of the above content and conditions, and the buyer or distributor agrees to assume any and all responsibility and liability for and hold AKM harmless from any and all claims arising from the use of said product in the absence of such notification.