

PART NUMBER	REV	FIRST USED
680196-2	C	565435-5
680196-3	C	354500-1

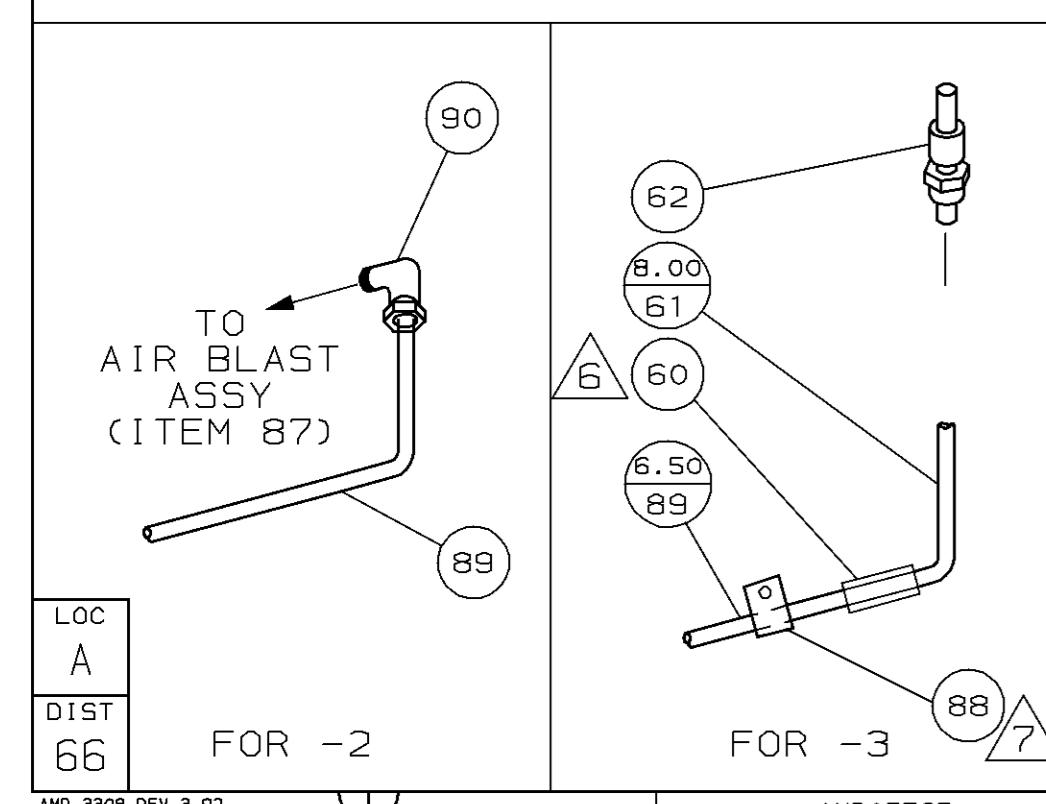
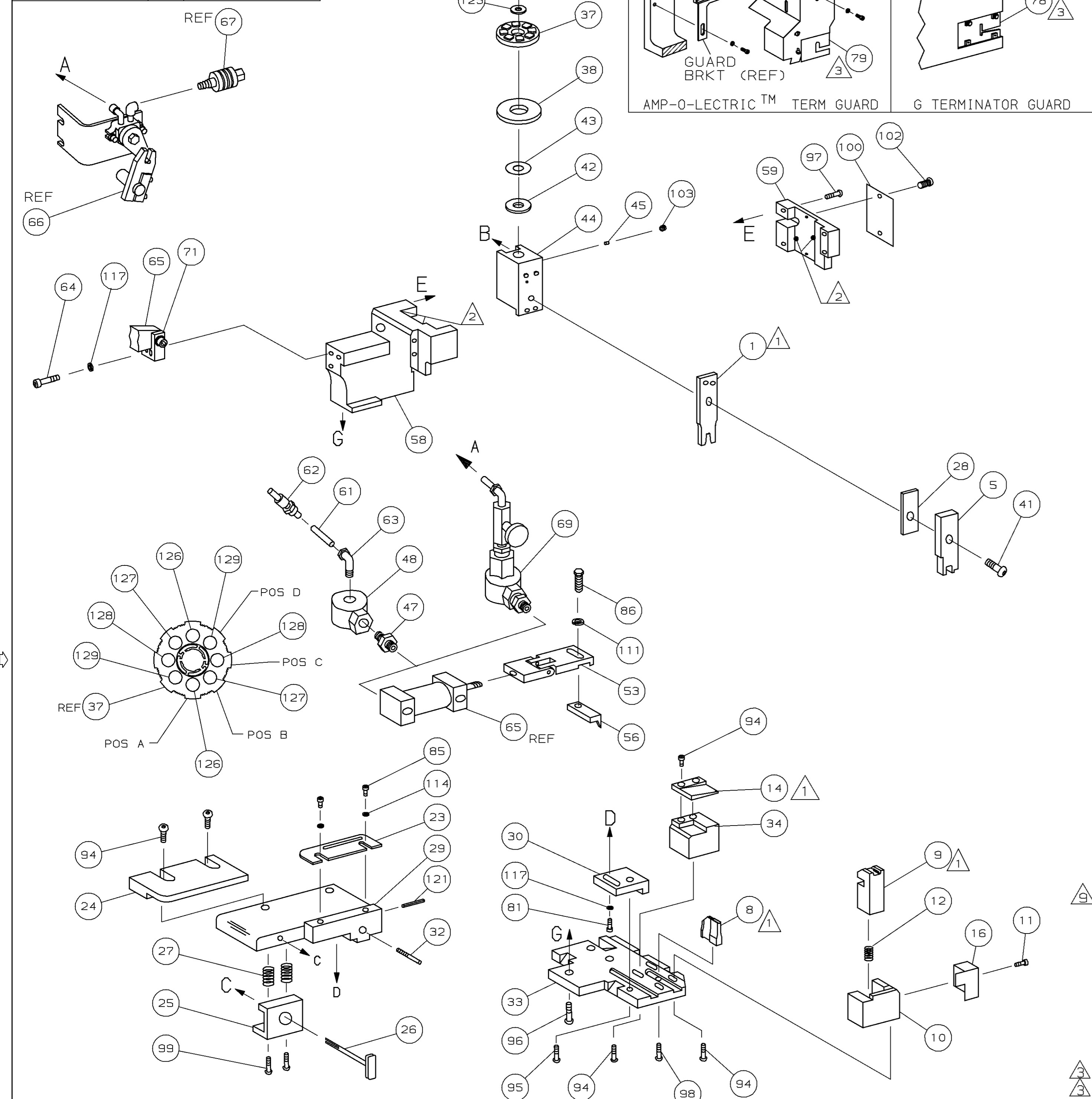

- 1 RECOMMENDED SPARE PARTS.
- 2 GREASE LIGHTLY.
- 3 GUARD MUST BE IN PLACE WHEN OPERATING APPLICATOR IN A BENCH MACHINE.
- 4 SEE DRAWING FOR COMPONENTS
- 5 WITH WIRE TRIM FEATURE
- 6 CENTER ITEM 60 BETWEEN ITEM 61 AND ITEM 89. ATTACH ITEM 60 TO ITEM 89 AND ITEM 61 USING ADHESIVE PN 28829-2.
- 7 INSTALL ITEM 88 TO ITEM 58 USING ITEM 84.
- 8 SET-UP ONLY
- 9 CUT TO 7 INCHES AT ASSY.

CRIMPING DATA			
PAD LTR	CRIMP HEIGHT	WIRE SIZE CMA	(#)
A	.072 ± .002 [1.83 ± 0.05mm]	4400-5000 1 (17)+1 (16 1/2)	2
B	.067 ± .002 [1.70 ± 0.05mm]	3400-4200 (14)	2
C	.062 ± .002 [1.57 ± 0.05mm]	2400-3200 (16)	2
D	.057 ± .002 [1.45 ± 0.05mm]	1400-2200 (18)	2
CRIMP	SIZE	TYPE	RANGE
WIRE	.110 [2.79mm]	F	1400-5000 CMA
INSUL	-	-	-

QTY	REQD	PER	ASSY	WIRE STRIP LENGTH	TERM	APPL	SPEC	FEED	APPL	INSTRUCTION	SET UP	GAGE	LAYOUT
2	2	-	C	-	-	-	-	.500	408-8040	PIN, WIRE DISC (.3090)D	458637-1	L1672	
2	2	-	C	-	-	-	-	-	-	PIN, WIRE DISC (.3045)C	-	-	
2	2	-	C	-	-	-	-	-	-	PIN, WIRE DISC (.3005)B	-	-	
2	2	-	C	-	-	-	-	-	-	PIN, WIRE DISC (.2930)A	-	-	
1	1	-	A	-	-	-	-	-	-	WASHER, FLAT PRECISION	-	-	
1	1	-	A	-	-	-	-	-	-	PIN, SLT SPR (#.093x.75)ST GDE PL	-	-	
1	1	-	A	-	-	-	-	-	-	WASHER, LOCK (#10) ADJ BLOCK	-	-	
3	3	-	A	-	-	-	-	-	-	WASHER, LOCK (#4) FRONT STP GUIDE	-	-	
2	2	-	A	-	-	-	-	-	-	WASHER, LOCK (#8)	-	-	
1	1	-	A	-	-	-	-	-	-	SCR, SKT SET (1/4-20x.25 LW) RAM	-	-	
2	2	-	A	-	-	-	-	-	-	SCR, DRIVE (#2x.19) ID PLATE	-	-	
1	1	-	B	-	-	-	-	-	-	PLATE, IDENTIFICATION	-	-	
2	2	-	A	-	-	-	-	-	-	SCR, BHC (10-32x.88) DRAG	-	-	
1	1	-	A	-	-	-	-	-	-	SCR, BHC (8-32x.38 LW) ANVIL	-	-	
4	4	-	A	-	-	-	-	-	-	SCR, BHC (10-32x.75) CAP	-	-	
3	3	-	A	-	-	-	-	-	-	SCR, BHC (1/4-20x.62) HOUSING	-	-	
1	1	-	A	-	-	-	-	-	-	SCR, BHC (10-32x.50) SG ADJ BLOCK	-	-	
8	8	-	A	-	-	-	-	-	-	SCR, BHC (8-32x.50) TERM H DWN	-	-	
-	1	-	A	-	-	-	-	-	-	ELBOW, METAL T .25T-1/8 NPT	-	-	
1	1	-	B	-	-	-	-	-	-	AIR BLAST TUBE	-	-	
1	-	-	A	-	-	-	-	-	-	CLAMP, WIRE	-	-	
-	1	-	C	-	-	-	-	-	-	AIR BLAST ASSEMBLY	-	-	
1	1	-	A	-	-	-	-	-	-	SCR, HEX HD (8-32x.31) FEED FINGER	-	-	
2	2	-	A	-	-	-	-	-	-	SCR, SHC (4-40x.25) F ST GUIDE	-	-	
1	1	-	A	-	-	-	-	-	-	SCR, SHC (10-32x.38) SG ADJ BL	-	-	
-	REF	-	B	-	-	-	-	-	-	GUARD, WINDOW	-	-	
REF	-	-	B	-	-	-	-	-	-	INSERT, GUARD	-	-	
1	1	-	B	-	-	-	-	-	-	MOUNT, FEED BRACKET	-	-	

QTY	REQD	PER	ASSY	WIRE STRIP LENGTH	TERM	APPL	SPEC	FEED	APPL	INSTRUCTION	SET UP	GAGE	LAYOUT
-2	-	-	C	-	-	-	-	-	-	BENCH MODEL K	-	-	-
-3	-	-	C	-	-	-	-	-	-	BENCH MODEL G	-	-	-
-	1	-	C	-	-	-	-	-	-	692655-5	-	-	70
-	REF	-	A	-	-	-	-	-	-	24042-2	-	-	69
-	REF	-	C	-	-	-	-	-	-	692655-6	-	-	68
1	1	-	B	-	-	-	-	-	-	461065-1	-	-	67
2	2	-	A	-	-	-	-	-	-	3-21000-7	-	-	66
1	-	-	A	-	-	-	-	-	-	983427-6	-	-	65
2	-	-	A	-	-	-	-	-	-	23238-1	-	-	64
6.00	-	-	IN	-	-	-	-	-	-	27319-4	-	-	63
2.00	-	-	IN	-	-	-	-	-	-	27319-3	-	-	62
1	1	-	C	-	-	-	-	-	-	454220-1	-	-	61
1	1	-	D	-	-	-	-	-	-	454485-1	-	-	60
1	1	-	B	-	-	-	-	-	-	690542-2	-	-	59
1	1	-	B	-	-	-	-	-	-	461062-1	-	-	58
1	-	-	A	-	-	-	-	-	-	22374-7	-	-	57
1	-	-	A	-	-	-	-	-	-	22304-1	-	-	56
1	1	-	A	-	-	-	-	-	-	690191-1	-	-	55
1	1	-	C	-	-	-	-	-	-	455673-1	-	-	54
1	1	-	A	-	-	-	-	-	-	690125-1	-	-	53
1	1	-	A	-	-	-	-	-	-	690124-1	-	-	52
1	1	-	A	-	-	-	-	-	-	7-21002-9	-	-	51
1	1	-	A	-	-	-	-	-	-	690223-2	-	-	50
1	1	-	D	-	-	-	-	-	-	354777-1	-	-	49
1	1	-	A	-	-	-	-	-	-	22480-5	-	-	48
1	1	-	B	-	-	-	-	-	-	690212-1	-	-	47
1	1	-	C	-	-	-	-	-	-	318548-1	-	-	46
1	1	-	D	-	-	-	-	-	-	455675-1	-	-	45
1	1	-	A	-	-	-	-	-	-	690432-3	-	-	44
1	1	-	B	-	-	-	-	-	-	455689-1	-	-	43
1	1	-	C	-	-	-	-	-	-	455671-1	-	-	42
1	1	-	C	-	-	-	-	-	-	1-455888-5	-	-	41
2	2	-	A	-	-	-	-	-	-	1-22284-0	-	-	40
1	1	-	B	-	-	-	-	-	-	690546-1	-	-	39
1	1	-	B	-	-	-	-	-	-	240792-1	-	-	38
1	1	-	D	-	-	-	-	-	-	6-690504-3	-	-	37
1	1	-	A	-	-	-	-	-	-	690438-1	-	-	36
1	1	-	B	-	-	-	-	-	-	318563-1	-	-	35
1	1	-	C	-	-	-	-	-	-	318547-1	-	-	34
1	1	-	A	-	-	-	-	-	-	5-22280-0	-	-	33
1	1	-	B	-	-	-	-	-	-	690461-1	-	-	32
1	1	-	C	-	-	-	-	-	-	690459-1	-	-	31
1	1	-	C	-	-	-	-	-	-	454276-1	-	-	30
1	1	-	C	-	-	-	-	-	-	805840-9	-	-	29
1	1	-	C	-	-	-	-	-	-	1-455889-3	-	-	28
1	1	-	C	-	-	-	-	-	-	318542-1	-	-	27

REVISION OF EACH ASSY NO (WHEN BLANK, USE DWG REVISION)													
QTY	REQD	PER	ASSY	WIRE STRIP LENGTH	TERM	APPL	SPEC	FEED	APPL	INSTRUCTION	SET UP	GAGE	LAYOUT
-3	-2	-	U/M	DWG SIZE	PART NO	DESCRIPTION	ITEM NO						
1	1	-	B	-	-	-	-	-	-	459610-3	-	-	71

LOC A  
DIST 66

FOR -2  
FOR -3

THIS DRAWING IS A CONTROLLED DOCUMENT FOR AMP INCORPORATED. IT IS SUBJECT TO CHANGE AND THE CONTROLLING ENGINEERING ORGANIZATION SHOULD BE CONTACTED FOR THE LATEST REVISION.

THIS INFORMATION IS CONFIDENTIAL AND IS DISCLOSED TO YOU ON CONDITION THAT NO FURTHER DISCLOSURE IS MADE BY YOU TO OTHER THAN AMP PERSONNEL WITHOUT WRITTEN AUTHORIZATION FROM AMP INCORPORATED, HARRISBURG, PA.