

X-Cite® XLED1 User Guide

X-Cite® XLED1 User Guide

035-00465R Rev.7

Made in Canada

Excelitas Canada Inc. 2015

All rights reserved

No part of this publication may be reproduced, transmitted, transcribed, stored in a retrieval system or translated into any language in any form by any means without the prior written consent of **Excelitas Canada Inc.**. Every effort has been made to ensure information in this manual is accurate; however, information in this manual is subject to change without notice and does not represent a commitment on the part of the authors.



Excelitas Canada Inc.
2260 Argentia Road
Mississauga ON L5N 6H7 CANADA

Trademarks

X-Cite® is a registered trademarks of **Excelitas Canada Inc.**. All rights reserved.
All other product names are trademarks of their respective owners. Any product or software photos shown are for reference only and are subject to change without notice.

No part of this publication may be reproduced, transmitted, transcribed, stored in a retrieval system or translated into any language in any form by any means without the prior written consent from Excelitas Canada Inc.. Every effort has been made to ensure information in this manual is accurate; however, information in this manual is subject to change without notice and does not represent a commitment on the part of the authors.

Table of Contents

1. Introduction	1
2. Safety	2
2.1 Glossary of Symbols	2
2.2 Safety Precautions	2
2.3 Principles of ESD Control	5
3. Getting Started	7
3.1 XLED1 Front Panel	8
3.2 XLED1 Back Panel	9
3.3 Optional Touch Screen Controller/ Swivel Stand	10
4. Installation Procedures	11
4.1 General Installation	11
4.2 LED Module/Driver and Dichroic Installation	12
4.3 Installing Excitation Filter Holders	16
4.4 Graphical User Interface (GUI)	18
4.5 Light Guide Auto-Detect	19
4.6 Inserting/Removing Light Guide	19
4.7 Installing the Collimating Adapter	21
5. Powering Up/Powering Down	22
6. Operating the GUI Control Panel	24
6.1 Main LED Screen	25
6.2 Set LED Triggers Screen	27
6.3 Trigger Graphs Screen	31
6.4 Maintenance Screen	32
6.5 Dichroic Values	35
6.6 Alarm Information	35
6.7 Clearing alarms	37
6.8 System Information	37
7. Operating the Optional Touch Screen Controller	38
7.1 Log-In Screen	39
7.2 Main LED Screen	41
7.3 Edit LED Name Screen	43
7.4 Set LED Triggers Screen	44
7.5 Trigger Graphs Screen	48
7.6 Maintenance Screen	49
7.7 Alarm Information	51
7.8 Clearing alarms	53
7.9 System Information	54
8. Live Cell Mode (on Live Cell Configuration units)	56
8.1 Enabling Live Cell Mode	56

8.2	Changing duty cycle in Live Cell Mode.....	57
9.	External Control	58
9.1	External Trigger Interface	58
9.2	Trigger Input/Sync Output Signals Requirements	60
9.3	I/O Signal Descriptions	60
10.	LED Module and Driver Replacement	62
11.	Dichroic Replacement	65
12.	Routine Care and Maintenance.....	67
12.1	General	67
12.2	Cleaning Procedure, XLED1 & Touch Screen Controller:	67
12.3	Handling and Cleaning of the LED Lens Assembly.....	68
12.4	Handling and Cleaning of the Dichroic	69
12.5	Tips to Prevent Premature Degradation of Light Guides.....	71
13.	Troubleshooting Symptom/Possible Cause	73
14.	Technical Specifications	75
15.	Environmental Conditions	77
16.	Regulatory Compliance.....	77
17.	Warranty.....	80
18.	Warranty Table.....	81
19.	Component Number Table	82
20.	Contact Information.....	83

Figures:

Figure 1	XLED1 Front Panel	8
Figure 2	XLED1 Back Panel Image.....	9
Figure 3	Touch Screen Controller	10
Figure 4	LED Module/Driver and Dichroic Locations	12
Figure 5	Locking Hub.....	13
Figure 6	Dichroic Replacement.....	15
Figure 7	Typical XLED1 LED Module	16
Figure 8	Inserting filter into filter holder.....	16
Figure 9	Attaching filter assembly to module	17
Figure 10	Light Guide Port	20
Figure 11	Collimating Adapter.....	21
Figure 12	Main LED Screen (GUI).....	25
Figure 13	LED Trigger Screen (GUI).....	27
Figure 14	Trigger Graphs Screen (GUI)	31
Figure 15	Maintenance Screen (GUI)	32
Figure 18	Dichroic Database (GUI).....	34
Figure 19	Alarm Code Screen (GUI).....	36

Figure 20 System Information (GUI).....	37
Figure 21 Log-In Screen (Touch Screen Controller)	39
Figure 22 Main LED Screen (Touch Screen Controller).....	41
Figure 23 LED Name Edit Screen (Touch Screen Controller).....	43
Figure 24 LED Trigger Screen (Touch Screen Controller).....	44
Figure 25 Trigger Graphs Screen (Touch Screen Controller)	48
Figure 26 Maintenance Screen (Touch Screen Controller)	49
Figure 28 Alarm Code Screen (Touch Screen Controller).....	51
Figure 29 System Information (Touch Screen Controller).....	54
Figure 30 Terminal Block Connectors	58
Figure 31 Locking Hub.....	62
Figure 32 LED Module and Driver Replacement	64
Figure 33 Dichroic Replacement	66

Tables:

Table 1 Front Panel LED Indicators	8
Table 2 Alarm Codes (GUI)	35
Table 3 Error Pop-up Screen Descriptions (GUI)	36
Table 4 Error Window Descriptions (GUI)	38
Table 5 Alarm Codes (Touch Screen Controller)	51
Table 6 Error Pop-up Screen Descriptions (Touch Screen Controller)	52
Table 7 Error Window Descriptions (Touch Screen Controller).....	55
Table 8 External Trigger Pin Assignments	59
Table 9 External Sync Out Pin Assignments (OUTPUT 5.5V, 8mA max).....	59
Table 10 China RoHS	79
Table 11 System Components Warranty	81
Table 12 Component Part Numbers	82

1. Introduction

The **X-Cite® XLED1 System** is intended for use in fluorescence microscopy illumination. It allows researchers the ability to excite fluorescence in samples being studied and characterize their location or behaviour.

The **X-Cite® XLED1 System** resets the standard in LED fluorescence microscopy illumination systems. The heart of the **X-Cite® XLED1 System** is the LED Modules/Dichroics available for use in multiple configurations and combinations, each with 20,000 hour guaranteed lifetime. The systems' ease of use is made possible by the innovative solid state LED technology incorporated into the design of the system along with simple to advanced triggering controls, plug and play Modules and system intelligence. An easy-to-use Graphical User Interface (GUI) module allows full control of each LED. Also available is the optional Touch Screen Controller, providing the full control and monitoring of each LED module as never before seen in such a form factor.

Refer to the website for all LED module/driver and Dichroic locations and combinations.

<http://www.excelitas.com/Pages/Product/X-Cite-LED-Module-Configurator.aspx>

The **X-Cite® XLED1 System** joins the Excelitas Technologies family of light systems offering the same high level of innovation, quality and reliability that our customers have come to expect.

Excelitas Technologies Corp. is a global technology leader focused on delivering innovative, customized solutions to meet the lighting, detection and other high-performance technology needs of customers. X-Cite®, formerly of Lumen Dynamics (which was acquired by Excelitas Technologies Corp. in November 2013) offers the Life Science and Analytical Instrumentation market a broad range of innovative lamp and LED fluorescence illumination and measurement solutions.

Excelitas recommends reading this manual to discover all the features available for the **X-Cite® XLED1 System**.

Please ensure that you register your XLED1 at:

http://www.excelitas.com/Pages/Support/Register_OX.aspx

X-Cite® XLED1

Enclosure containing all opto-mechanical assemblies, control electronics and port interfacing.

Touch Screen Controller (optional)

Separate (remote) enclosure with touch screen display module for control of the XLED1.

Thank you for choosing X-Cite®!

2. Safety

2.1 Glossary of Symbols



Caution risk of danger – consult accompanying documents



Input/Output Signals



Input Signal



Output Signal



**RISK GROUP 2
CAUTION**

Possibly hazardous optical radiation/UV emitted from this product.
Use appropriate shielding
IEC 62471-2:2009
For detailed information contact Excelitas Canada Inc.



This product has been tested to the requirements of CAN/CSA-C22.2 No. 61010-1, second edition, including amendment 1, or a later version of the same standard incorporating the same level of testing requirements.



ATTENTION

Electro Static Discharge (ESD)
Observe precautions for handling Electrostatic Sensitive Devices

2.2 Safety Precautions

This series of cautions and warnings relate to the operation and maintenance of the **X-Cite® XLED1 System**. They are also presented throughout this User's Guide where necessary.



**RISK GROUP 2
CAUTION**

Possibly hazardous optical radiation/UV emitted from this product. Use appropriate shielding. IEC 62471-2:2009



WARNING

Visible and invisible radiation is emitted from the aperture of the Light Guide- avoid exposure to beam. Never look into the light emitting end of the Light Guide. The light could

severely damage the cornea and retina of the eye, if the light is observed directly. Eye shielding and protective clothing must be used at all times to protect exposed skin.

CAUTION



Use of the XLED1 system is intended ***only*** for microscopes using Excelitas Technologies collimating adaptors. Any attempt to use this system with a microscope not approved by Excelitas Technologies is not recommended and may impair system safety.



WARNING

Always make sure the Light Guide is properly inserted into the XLED1 and into the microscope, prior to turning on power to the unit. This will minimize the risk of exposure to UV light.



CAUTION

Removal of the service cover is intended for qualified technical personnel only! No user serviceable parts are located within the XLED1 chassis or the Touch Screen Controller. This system contains hazardous voltages-do not attempt to remove access covers while equipment is energized.



WARNING

To reduce the risk of fire or shock, always replace the AC mains fuses with the same type and rating (F6.3A, 250V). Ensure that the **X-Cite® XLED1 System** external power supply cord is connected to a grounded (earthed mains socket) 3-pin outlet only! Use only the power supply cord set provided with the system. Substitution is not recommended; operation and/or performance may be affected and may impair operating safety.



WARNING

The Level of UV and visible energy supplied by the **X-Cite® XLED1 System** is sufficient to ignite flammable substances. During installation in an automated environment the appropriate measures must be included to prevent any such occurrence.

**WARNING**

Should the **X-Cite® XLED1 System** be used in a manner not specified by Excelitas Technologies, the protection provided by the equipment may be impaired. Do not attempt to connect the Touch Screen Controller to any type of electrical equipment other than the XLED1 main system as indicated in Figure 2 of this manual.

**WARNING**

This unit is designed for bench top use only! Always ensure that the unit is operated on a hard, stable surface. This will prevent obstruction of the bottom chassis ventilation openings. Any obstruction of these openings could result in a possible over-heating condition. Do not attempt to remove or tamper with the rubber feet located on the bottom of the unit.

**CAUTION**

Use of controls or adjustments or performing procedures other than those specified herein may result in hazardous radiation exposure.



The Light Guide operation can be affected if handled incorrectly. Never touch the light emitting end of the Light Guide. The presence of skin oils may result in a decrease in system performance.



Always ensure the system power is turned off, prior to disconnecting or re-connecting the Light Guide.

**CAUTION**

To prevent damage/ degradation of the Light Guide, always allow adequate clearance at the front of the XLED1 unit to prevent kinking or excessive bending.

**WARNING**

Do not lift the XLED1 from the rear of the removable housing when system is either on or off.

**CAUTION**

To protect the LED module, driver and system from electrostatic related damage, which can disable the system, permanently damage the LED module & driver, or require repair by service technicians, place all Modules on an antistatic surface, such as an antistatic discharge mat, an antistatic bag, a disposable antistatic mat or a grounded metal surface. If possible, wear an antistatic grounding strap connected to a metal surface on the chassis when you replace any LED module or LED driver. Refer to [section 2.3](#) for understanding the principles of ESD control.

2.3 Principles of ESD Control

The basics of electrostatic charge, discharge, types of failures, ESD events, and device sensitivity may be summarized as follows:

- Virtually all materials, even conductors, can be triboelectrically charged, (an electric charge generated by friction).
- The level of charge is affected by material type, speed of contact and separation, humidity, and several other factors.
- Electrostatic discharge can create catastrophic or latent failures in electronic components.
- Electrostatic discharge can occur throughout the manufacturing, test, shipping/handling, or operational/repair processes.
- Component damage can occur as the result of a discharge from the component as well as a direct discharge to the component.
- Components vary significantly in their sensitivity to ESD.

The best method of preventing ESD is to use an ESD wrist strap, a grounding mat or a metal table. However, since most users do not have access to such items, we have provided the following guidelines to help reduce the risks and levels of ESD:

- **Zero Potential** - Most importantly, make sure you and the system are at Zero Potential by continuously touching an un-painted metal surface of the chassis or the grounded table.
- **Standing** - It is also very important that you are standing at all times when working on the system. Sitting on a chair can generate more electrostatic energy.
- **Cords** - Make sure everything is removed from the back of the system (power cord, touch controller, interface cables, etc).
- **Clothes** - Make sure not to wear any clothing that conducts Electrical Charge, such as a wool material.
- **Weather** - Electrical storms can increase the ESD risk; unless absolutely necessary, try not to work on the system during an electrical storm.
- **Accessories** - To help reduce ESD and help prevent other problems, it is also a good idea to remove all jewellery.

With this basic understanding of ESD and its impact on your environment, you can then begin to develop an effective ESD control program by reducing as many static generating processes or materials as possible, such as the contact and separation of dissimilar materials and common plastics from the work environment. Keep other processes and materials at the same electrostatic potential. Electrostatic discharge does not occur between materials kept at the same potential or at zero potential. Therefore, provide ground paths, such as a wrist strap or a conductive surface connected to ground, to allow static accumulating in yourself and/or materials nearby to discharge to ground rather than to critical components.

Prevent discharges that do occur from reaching susceptible parts and assemblies. Package and transport susceptible devices in proper packaging and materials-handling products. These materials may effectively shield the product from charge, as well as reduce the generation of charge caused by any movement of product within the container. Such products include ESD shielded bags, conductive totes, and antistatic packaging materials.

Helpful ESD Links:

http://en.wikipedia.org/wiki/Electrostatic_discharge

http://en.wikipedia.org/wiki/Electrostatic_sensitive_device

<http://www.ipc.org/ContentPage.aspx?pageid=IPC-and-ESDA-Collaborate-on-Required-ESD-Training-for-Electronics-Assembly-Operators>

<http://www.ce-mag.com/99ARG/ESD%20Assoc175.html>

3. Getting Started

System Components

Carefully unpack the system and accessories. As you remove each item from the box place a check mark next to each item to ensure that all **ordered** components are present. Store the packaging and packing materials for future use.

Box Contents Check List

- | | |
|---|--------------------------|
| 1. XLED1 + ordered modules and dichroics | <input type="checkbox"/> |
| 2. AC Cord | <input type="checkbox"/> |
| 3. USB Cable..... | <input type="checkbox"/> |
| 4. XLED1 Locking Hub Key..... | <input type="checkbox"/> |
| 5. Locking Hub Key Hanger (refer to Figure 2 for install location).... | <input type="checkbox"/> |
| 6. XLED1 Quick Start Guide
(User Guide, Software and Driver downloads:
http://www.excelitas.com/Pages/Product/X-Cite-XLED1.aspx)..... | <input type="checkbox"/> |
| 7. Product Registration Card | <input type="checkbox"/> |
| 8. XLED1 Excitation filter holders (set of 4)..... | <input type="checkbox"/> |
| 9. XLED1 trigger cable..... | <input type="checkbox"/> |

Please go online to register at http://www.excelitas.com/Pages/Support/Register_OX.aspx

- Refer to [Table 12](#) for individual part numbers
- If your packaged system is missing any of the listed components, call Excelitas Technologies at (905) 821-2600 or Toll Free 1-800-668-8752.

Refer to the website for all LED module/driver and Dichroic locations and combinations.

<http://www.excelitas.com/Pages/Product/X-Cite-LED-Module-Configurator.aspx>

3.1 XLED1 Front Panel

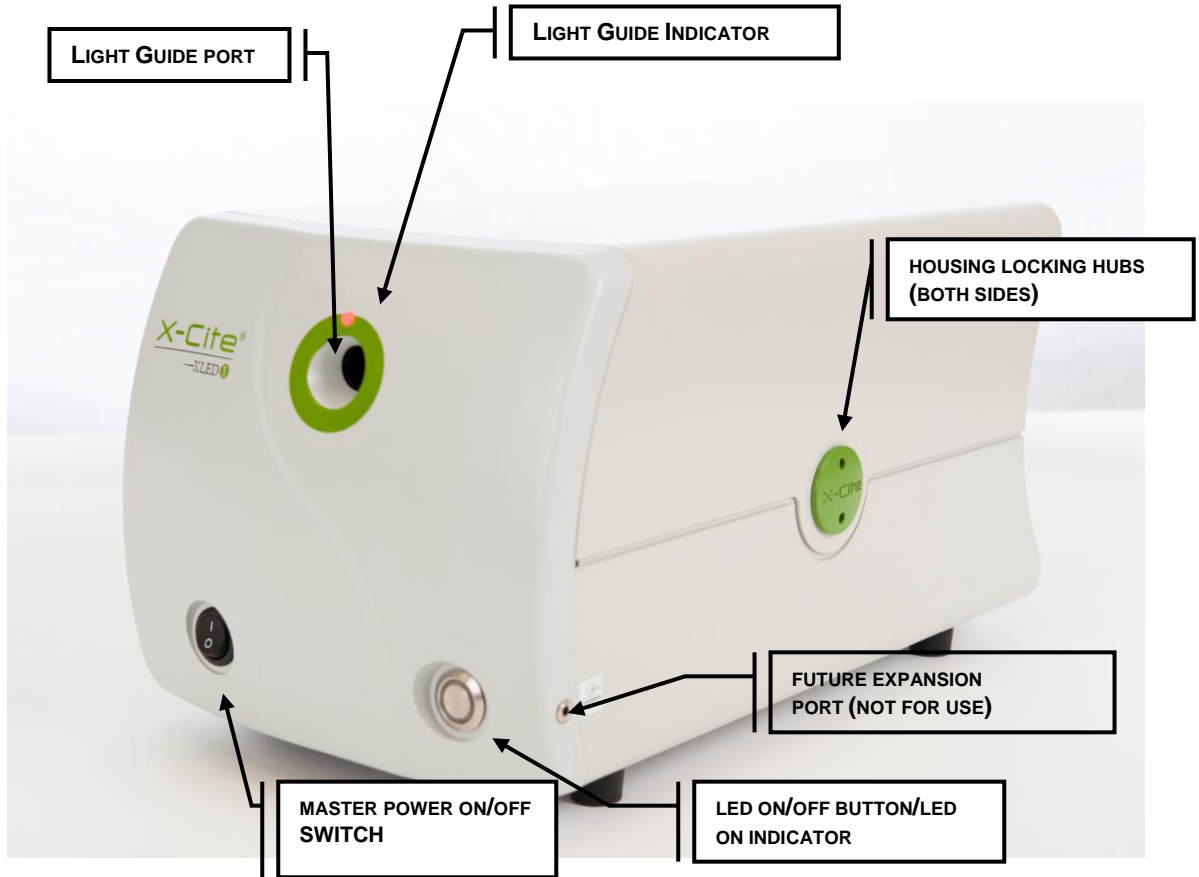

Figure 1 XLED1 Front Panel

LED Indicator	Status	Description
Light Guide LED	Green	Light Guide fully inserted
	Red	Light Guide not fully inserted
	Yellow	Live Cell Mode
LED ON	Green	Enabled (On)
	No Illumination	Disabled (Off)

Table 1 Front Panel LED Indicators

3.2 XLED1 Back Panel

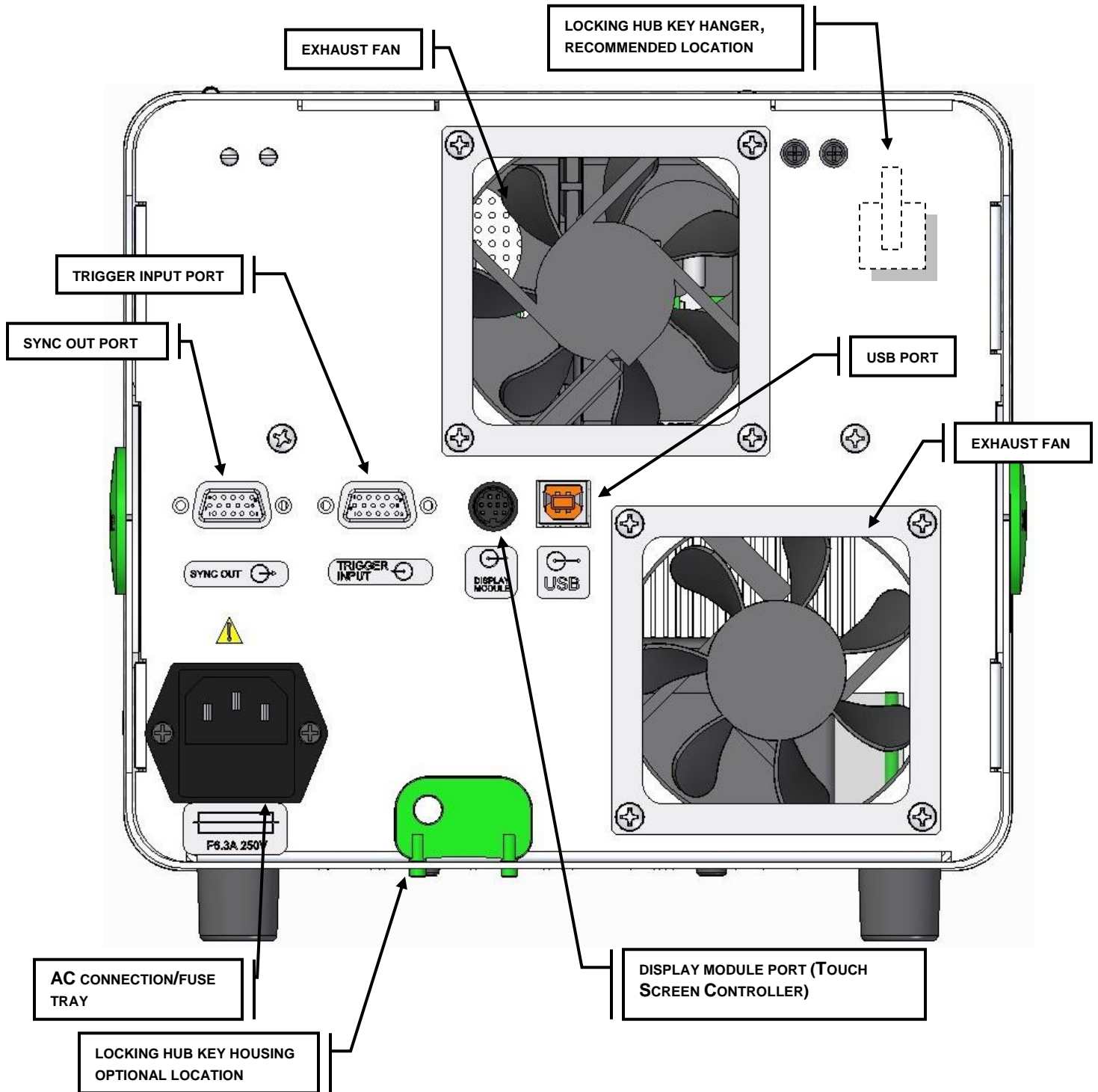

Figure 2 XLED1 Back Panel Image

3.3 Optional Touch Screen Controller/ Swivel Stand

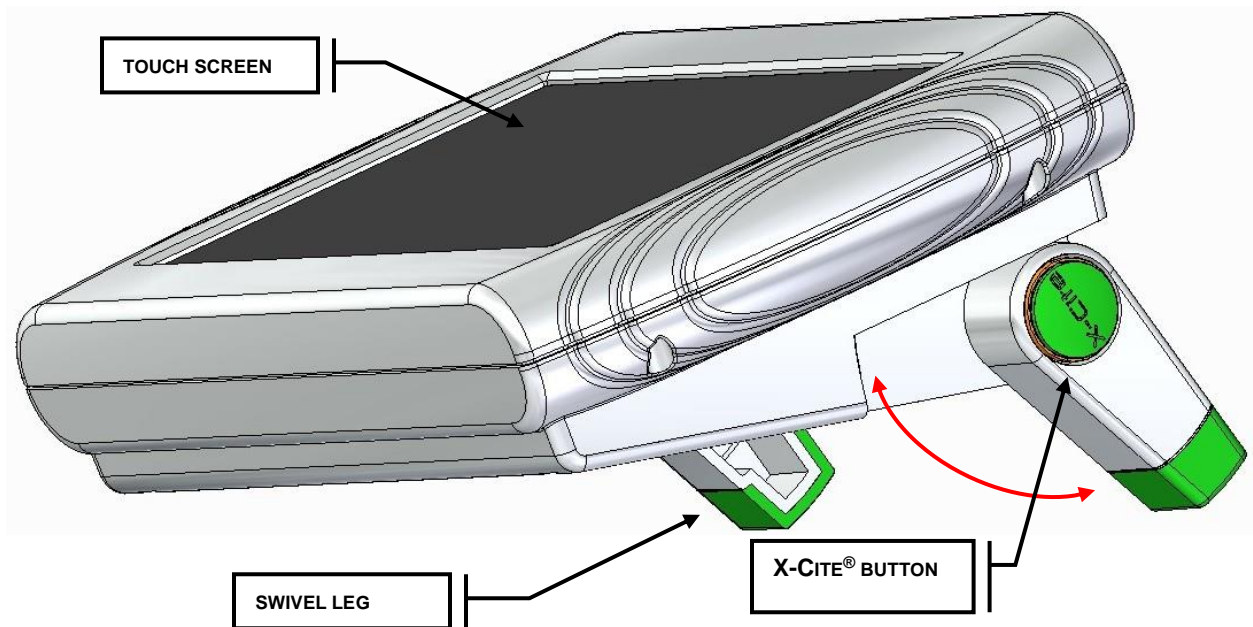

Figure 3 Touch Screen Controller

The optional Touch Screen Controller has a stand made up of two separate extendable legs that swivel out from the back of the Touch Screen Controller. Refer to [Figure 3](#).

To swivel the legs out, push in the green X-Cite® button and swivel the leg out to one of the pre-set stops to achieve the optimal viewing angle. Repeat for the other leg.

To retract the legs push in the green X-Cite® button and swivel the legs back into the body of the controller.

4. Installation Procedures

4.1 General Installation



Note: Before any installation occurs ensure there is a minimum space allowance of 50mm surrounding XLED1 to maintain acceptable airflow performance. Airflow is exhausted from the rear of XLED1.

Excelitas Technologies recommends installing the locking hub key hanger. Bend the flexible tang into a hook shape, peel off the protective backing and affix to the recommended location shown on the rear panel in [Figure 2](#).

Do not use the removable cover as a means to lift the XLED1. It is recommended that the XLED1 and the optional Touch Screen Controller are mounted on flat stable surface/platform adjacent to microscope.

If purchased, connect the optional Touch Screen Controller to the display module connection provided at the rear of the XLED1 panel. Refer to [Figure 2](#).

Note: Do not use both the GUI Control Panel and the Touch Screen Controller at the same time.

If Triggering is required, connect the 15pin HD-DB15 trigger I/O breakout cables to the trigger input and sync output connections located on the back XLED1 panel, refer to [Figure 2](#).

If interfacing with the GUI Control Panel, connect the computer to XLED1 via the USB connection located on the back panel.

Connect the AC cable to the AC connector on the back of the XLED1 panel.

4.2 LED Module/Driver and Dichroic Installation

The XLED1 system ships with the LED Modules, Drivers and Dichroics uninstalled and in separate boxes. These need to be installed according to the instructions below.

- On line configurator at <http://www.excelitas.com/Pages/Product/X-Cite-LED-Module-Configurator.aspx> for module configurations and locations.

“Location” refers to the positions identified in Figure 4, showing an empty X-Cite® XLED1 unit. (yellow = Dichroic location, blue = LED module and driver location). For LED Module/Driver and Dichroic Replacement instructions, refer to sections 10 and 11.

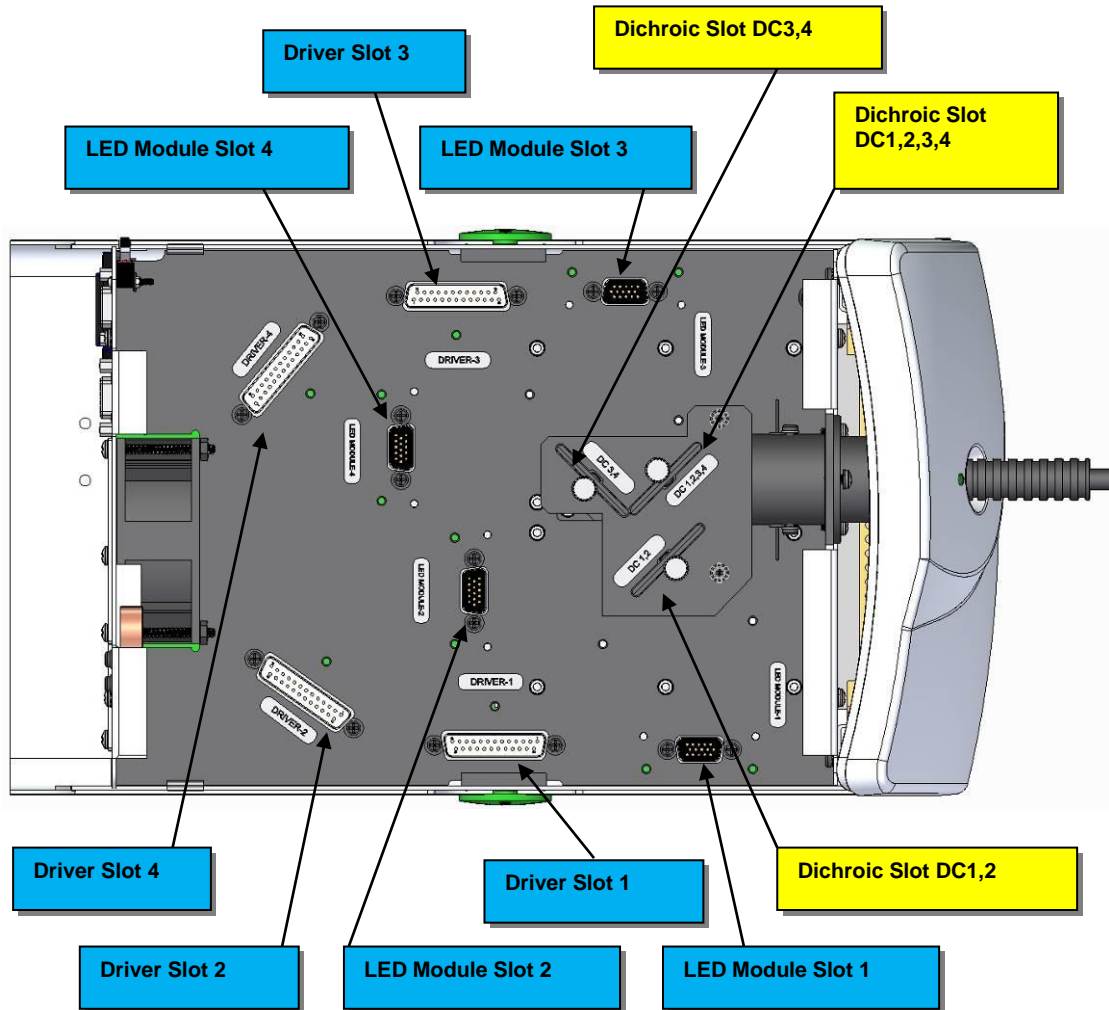

Figure 4 LED Module/Driver and Dichroic Locations



CAUTION

To protect the LED Module, Driver and system from electrostatic discharge (ESD) related damage, which can disable the system, cause latent defects or permanent

damage, or require repair by service technicians, please take the following ESD prevention steps:

- Ensure the unit is unplugged
- Ensure you are properly grounded, ideally by using an ESD grounding strap attached to an ESD protective surface.

Refer to [section 2.3](#) for principles of ESD and additional ESD precautions.



Tools Required: Locking Hub Key (supplied)
#2 Philips Head Screwdriver (not supplied)
Torque tool (not supplied)

**LED Modules, Drivers and Dichroics are shipped in ESD bags.
LED Modules are shipped with a protective lens cap covering the LED lens.**

Ensure the system is OFF and the AC power cord is unplugged from the power source.

Using the locking hub key supplied, rotate the green locking hubs 90 degrees and remove the locking hubs. Holding the XLED1 housing at the back, slide the XLED1 housing up and back (away from the fascia) for removal. The locking hub key can be stored on the locking hub key hanger, located on the back panel of XLED1.

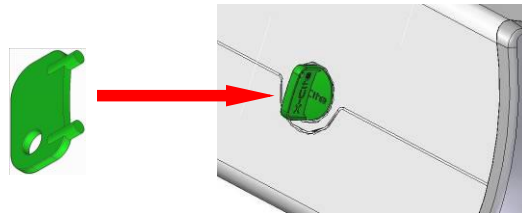

Figure 5 Locking Hub

LED Modules are shipped with their unique Drivers. Both components must be installed at the same time. Refer to [Figure 4](#) for module and Dichroic locations.



Caution: Do not touch the LED lens surface. Skin oils and scratches can cause the optical output to decrease.



Caution: The Dichroic window operational life can be significantly shortened if it is handled incorrectly. Do not touch the window surface. Skin oils and scratches can cause the window to fail prematurely. Refer to [section 12.3](#) for handling and cleaning instructions.

To install the LED Module and Driver, first remove the protective LED lens cap from the LED Module. Align the LED module/driver male pins with the female socket connection and gently push down into place. Tighten the Philips-Head screws until a positive force is felt and apply ¼ turn. **DO NOT OVER TIGHTEN THE SCREWS. (If using a calibrated torque-meter, Excelitas Technologies recommends a torque value of 5.7 lb-in/± 0.3 lb-in.)**

If there is a mismatch installation of either standard powered or high powered Drivers, the corresponding LED will not operate.

Install the Dichroics by inserting through the slot and lightly press down until a positive force is felt. Ensure to hand tighten the locking screw, do not use mechanical tooling such as screwdrivers, pliers etc. Refer to [Figure 4](#) for Module and Dichroic locations.

If the Dichroic is inserted incorrectly, the Dichroic's orientation key (located on the frame), will not pass through the cut-out on the top plate, resulting in an unseated Dichroic. Refer to [Figure 6](#).

When changing a Dichroic the Edge value must be manually entered into the system. If using the GUI Control Panel Refer to [section 6.4](#) and [Figure 18](#). For instructions on changing the Edge, reflect and transmit values.

If using the Touch Screen Controller, to change the Edge value, touch on the Dichroic to see the pop-up window, touch the top tab of the window and an edit screen will appear. Type in the new Edge value and press "GO" to return to the maintenance screen. The edge value is printed on the Dichroic module. For new Dichroics, the reflect and transmit values will not be automatically updated, refer to [section 6.5](#) for these values.

Replace the XLED1 housing ensuring a snug fit. Insert the locking hubs and using locking hub key supplied, rotate the green locking hubs to the locked position. Return the locking hub key to the locking hub key hanger, located at the rear of the system. The system will not allow the main power switch to function if the housing is not replaced properly.

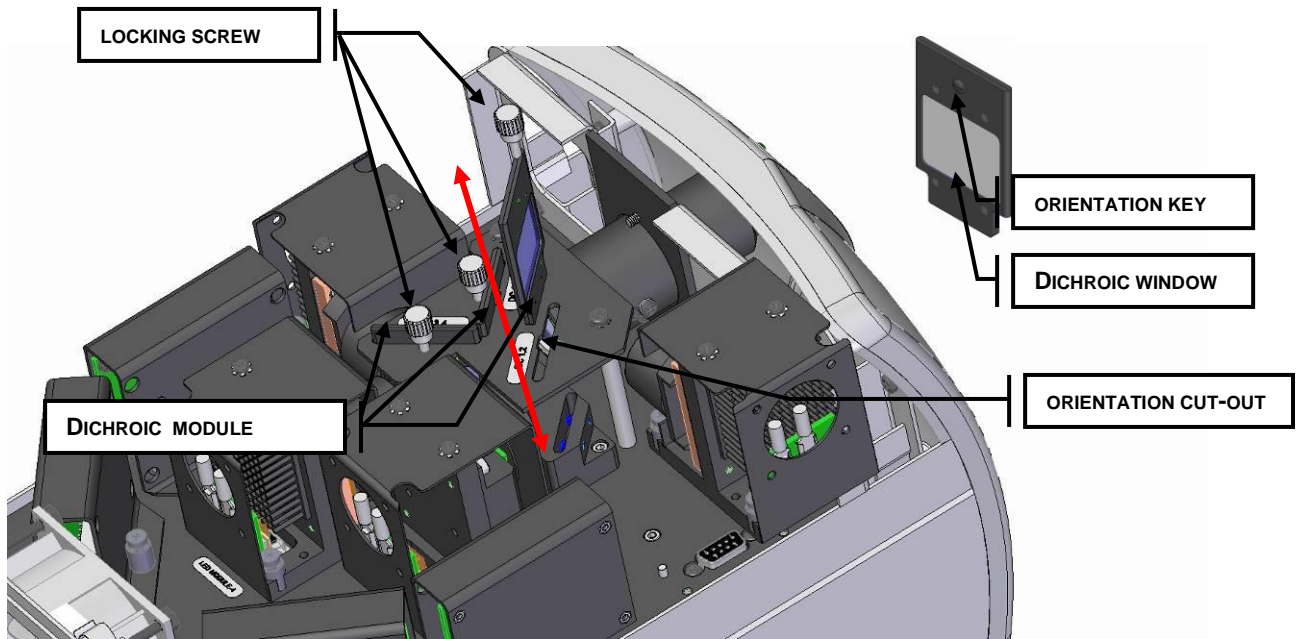

Figure 6 Dichroic Replacement

4.3 Installing Excitation Filter Holders

All XLED1 units include 4 filter holders that accommodate any standard 25mm band-pass filter. Additional filter holders can also be ordered separately by using part number 019-00175R.

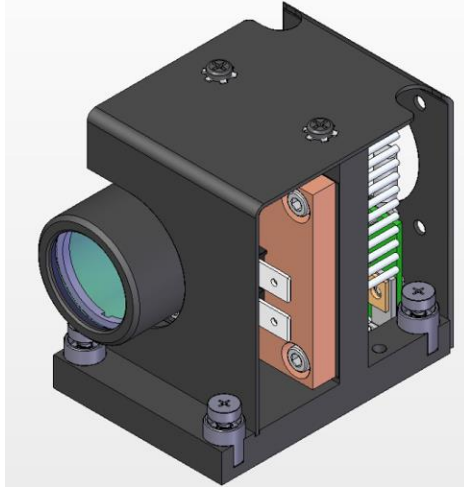

Figure 7 Typical XLED1 LED Module

Follow instructions as per section 4.2 of the XLED1 user manual to open the XLED1 system and remove the LED module of interest. Only remove the LED module, there is no need to remove the driver.

NOTE: care must be taken to not contaminate or damage the lens or excitation filter (wearing gloves is recommended when performing this procedure).

Place the filter holder on a flat clean surface as shown below.

With the arrow (indicating the coated side of the filter) pointing upward, place the filter inside the filter holder (Figure 8) and tighten the set screw with supplied allen key

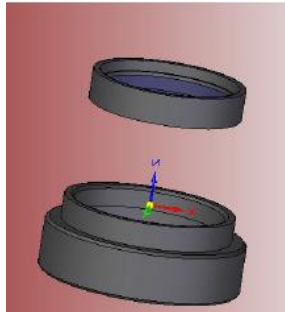

Figure 8 Inserting filter into filter holder

Attach the excitation filter + filter holder into the LED module lens as depicted below and secure the set screw with the provided allen key

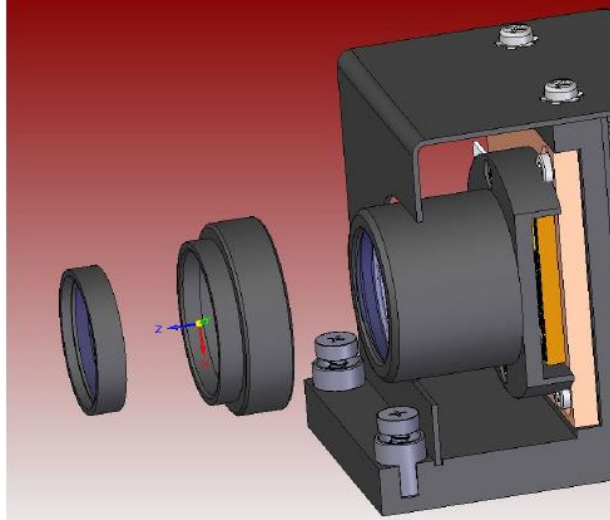

Figure 9 Attaching filter assembly to module

Re-insert the LED module into the XLED1 system.



Note: Utmost care must be taken to not contaminate the lens or the Excitation filter. e.g., finger prints, dust, etc. The use of gloves or other material suitable for handling optics is recommended.

4.4 Graphical User Interface (GUI).

Note: Ensure user is logged in as Administrator. The USB drivers and GUI can be downloaded from our website under the “SOFTWARE DOWNLOADS” section of the Resource Centre. <http://www.excelitas.com/Pages/Product/X-Cite-XLED1.aspx>

System Requirements:

Operating System:

Windows XP 32/64bit, Windows Vista 32/64bit, Windows 7 32/64bit, Windows 2003 Server 32/64bit, Windows 2008 Server 32/64bit, Windows 2008 R2.

Minimum Hard Drive Space: 5MB

1. Installation of USB Drivers (from web/windows update)

1. Log on to internet.
2. Connect USB cable from XLED1 to computer.
3. Turn on XLED1.
4. “Found New Hardware” will appear on the computer screen.
5. “Found New Hardware Wizard” will appear on the computer screen.
6. Select “Install Software Automatically (Recommended)” click “Next”.
7. Once wizard finds software click on “Finish”.
8. Follow instructions for GUI Installation.

Note: If window pops up with “search on-line for driver” click yes.

2. Alternative Installation Option

Use MS Windows update as per your computer operating system.

Look for:

1. “Excelitas Technologies Hardware XLED1”.
2. Follow download instructions.
3. Repeat for 2nd Driver (1st install is USB Base Driver, 2nd install is Virtual Serial/com Port.)
4. Locate downloaded Drivers in your Device Manager.
5. Follow instructions for GUI Installation.

Note: Ensure Installation of USB Drivers has been completed before installing the GUI.

3. Installation of GUI Control Panel (from ZIP File):

1. Connect to the internet.
2. Download GUI Control Panel Software from our website:
<http://www.excelitas.com/Pages/Product/X-Cite-XLED1.aspx>
3. The USB Driver must be installed first. Refer to paragraphs 1 or 2 in this section.

4. In your downloads folder, search for and open the “032-00136.zip” file.
5. Double click on SETUP.EXE
6. Next follow the setup instructions as they appear by clicking “next” each time the user prompt appears, until the installation has been completed and “finish” appears. Click on “finish” to complete the installation.

Note: A Software Development Kit (SDK) 035-00469R is available upon request. This SDK will permit computer control of functions described in the serial command sets. Please contact Excelitas Technologies to request this document, (refer to [section 20](#)).

4.5 Light Guide Auto-Detect

The system will not allow the enabling of LED sources if there is not a Light Guide present in the receptacle.

The system will disable all LED sources if the Light Guide has been detected as “removed” from the unit. Refer to [section 4.6](#) for Light Guide installation.

The lightguide LED on the front panel of XLED1 will illuminate green indicating the Light Guide insertion is correct. If the Light Guide is not fully inserted the Light Guide indicator LED will illuminate RED, (there will be 3 beeps from the optional Touch Screen Controller). The error icon will illuminate on the GUI Control Panel or on the Touch Screen Controller.

The system will not allow the main power switch to function if the housing is not replaced properly. When replacing the XLED1 service housing, ensuring a snug fit and using locking hub key supplied, rotate the green locking hubs to the locked position.

4.6 Inserting/Removing Light Guide

Ensure that the main power is off on the XLED1 unit.

Ensure the power cord is not connected to XLED1.

Ensure that the protective end caps are removed from both the input and output ends of the Light Guide prior to installation and remove plastic plug (if present) from the Light Guide port on the front panel of XLED1.

Hold the Light Guide by the grey sleeve/strain relief portion only, insert the Light Guide into the Light Guide port. Push the Light Guide in until it seats with a positive "click" (up to the “A” line printed on the grey ferrule).



Note: *Never grip the Light Guide during installation or removal in a place other than the reinforced strain relief portion of the Light Guide.*

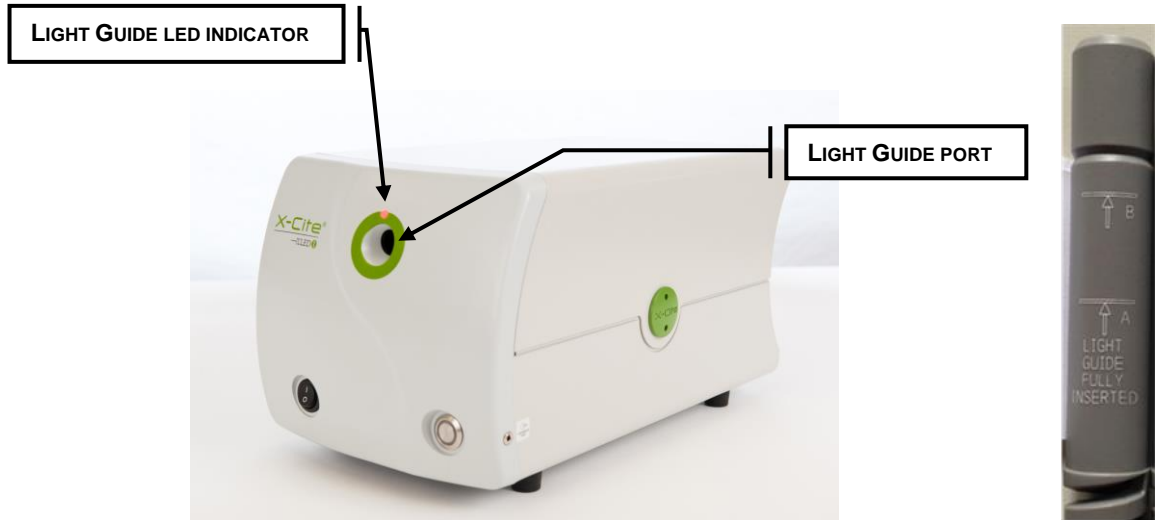

Figure 10 Light Guide Port

During use, when the Light Guide is fully inserted the Light Guide LED indicator will illuminate green indicating full Light Guide insertion. If the Light Guide is not fully inserted when the unit is powered up, the Light Guide indicator LED will be RED, (there will be 3 beeps from the optional Touch Screen Controller). The error icon will illuminate on the GUI Control Panel or on the Touch Screen Controller.

To remove the Light Guide, firmly grip the strain relief near the Light Guide retainer and pull out firmly.



Note: *XLED1 is designed for use with a 3mm liquid Light Guide. Excelitas Technologies cannot guarantee the performance of the system if using Light Guides other than those supplied by Excelitas Technologies.*



Note: Refer to [section 12.5](#) for tips to prevent premature degradation of Light Guides.

4.7 Installing the Collimating Adapter

Ensure that the main power is off on the XLED1 unit.

The existing lamp housing must be removed from the microscope before the Collimating Adapter can be mounted. Do not discard the existing mounting hardware, since it will be used to secure the Collimating Adapter to the microscope.

Remove the Collimating Adapter from its packaging.



Note: *The Collimating Adapter has been set at the factory. No adjustments by the customer are required; however some adapter models are outfitted with centering set screws, for longer light path applications. Separate instructions are included with these models.*

Insert the flange portion of the Collimating Adapter into the lamp port of the microscope. Using the existing hardware, tighten the screw(s) until the flange is fully secured.



Note: *The installation of the Collimating Adapter will vary with microscope models.*

Remove the protective cap from the output end of the Light Guide. Insert the Light Guide into the input portion of the Collimating Adapter until it is flush with the adjustable insert. Secure the Light Guide to the Collimating Adapter by tightening the thumbscrew. Do not over tighten.



Note: *The Light Guide has a minimum bend radius of 1.6 inches (40.0mm). Bending or coiling the Light Guide tighter than this radius will result in permanent damage to the Light Guide.*

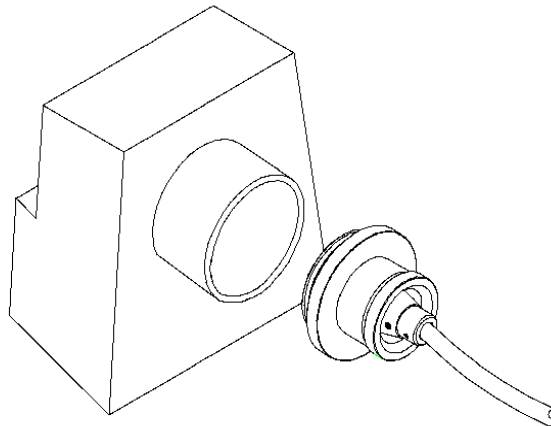

Figure 11 Collimating Adapter

5. Powering Up/Powering Down



Note: *Use UV Safety Eye Glasses before powering up the system.*

- The system will be fully operational under fluorescent or incandescent lighting.
- The system will be fully operational under zero lighting (darkness).
- The system will be fully operational in any daylight level other than direct incident sunlight.

Ensure that the Light Guide has been properly installed as per instructions in [section 4.6](#). If the Light Guide is not fully inserted the Light Guide indicator LED will be RED, (there will be 3 beeps from the optional Touch Screen Controller). The error icon will illuminate on the GUI Control Panel or on the Touch Screen Controller.

Ensure the master power switch is OFF. Plug the XLED1 power adaptor into a properly grounded electrical outlet.

Push the master power switch to 'ON' and ensure that the internal fans are operational. The cooling fans will remain functional throughout the complete start-up to power-down cycle.

The LED 'ON' indicator light will be off (No Illumination).

Open the GUI Control Panel at this time or if the optional Touch Screen Controller is connected, wait for the XLED1 logon screen.

Note: *Do not use both the GUI Control Panel and the Touch Screen Controller at the same time.*

Note: Do not connect the XLED1 Touch Screen Controller when the XLED1 is powered on.

The system will commence with a Power-On-Self-Test (POST). **All outputs will be inactive and all inputs will be unresponsive during the POST cycle, which takes approximately 60 seconds.** In the event of a POST error, the system will report the error and either allow the user to proceed or halt, depending on the error condition. Refer to [section 7.7](#) for alarm information if using the Touch Screen Controller. Refer to [section 6.6](#) for alarm information if using the GUI Control Panel.

During the POST sequence the system stabilization will:

- Check for number of LED Modules installed.
- Read LED module ID, check hours and check System LED NVM write capability.
- Ensure LED and driver type match.
- Check LED module thermistor.
- Check for alarms.
- Check for Pulse Generator Module.
- Check for connected Light Guide.
- Check for connected Touch Screen Controller.

If using the GUI Control Panel, once the system runs through and has exited the POST sequence the system is ready to use, there is no reset or warm up sequence required.

To power down the system after use, ensure all LEDs are off, click on the log out pad on the GUI Control Panel and push in the master power button to turn the XLED1 system off.

All previous settings in the GUI Control Panel will be saved.

If Using the Touch Screen Controller:

If using the optional Touch Screen Controller, once the system runs through and has exited the POST sequence the Touch Screen Controller screen will turn on automatically and the system is ready to use, there is no reset or warm up sequence required. If the Light Guide is not fully inserted the Light Guide indicator LED will be RED and there will be 3 beeps from the Touch Screen Controller and the light guide icon will illuminate at the top of the screen.

To enter the system at the **Log-In Screen**, follow the instructions in [section 7.1](#).

If logged in as a 'Guest' data will **not** be saved after completion of session.

Before powering down the system navigate to the **Main LED Screen** ([section 7.2](#)) and press the **LOG-OUT** pad. This will ensure all data entered from the latest session is saved. Failure to logout before powering down the system will result in loss of all recently changed settings.

To power down the system after use, ensure LED button is OFF, push the master power switch to the 'OFF' position.



Note: *Ensure that users **log-out** of the Touch Screen Controller before powering down or all entered data from the latest session will not be saved. (refer to [section 7.2](#)). The system is defaulted **NOT** to save any data when logged in as 'Guest' regardless of logging out or not.*

6. Operating the GUI Control Panel

Screen Sitemap:

- Main LED Screen (refer to [section 6.1](#))
- Set LED Triggers (refer to [section 6.2](#))
- Trigger Graphs (refer to [section 6.3](#))
- Maintenance (refer to [section 6.4](#))
- Alarm Information (refer to [section 6.6](#))
- System Information (refer to [section 6.8](#))

Note: all screens have a top bar indicator

- **Touch Screen Locked:** Disabled.
- **Light Guide Inserted:** Illuminates when the Light Guide is properly inserted.
- **Alarm:** Indicates a system alarm, user should navigate to the Alarm Screen to determine the source of the alarm.
- **LED on:** Illuminated when any LED Module is on.

6.1 Main LED Screen



Figure 12 Main LED Screen (GUI)

The main screen displays a section for each LED module (e.g: UVX, BDY, BGX and RLX), these can be renamed to desired fluorophores. Click on the desired wavelength name to view the wavelength range or to rename the LED. Enter a name or number and press OK. The display will now be changed.

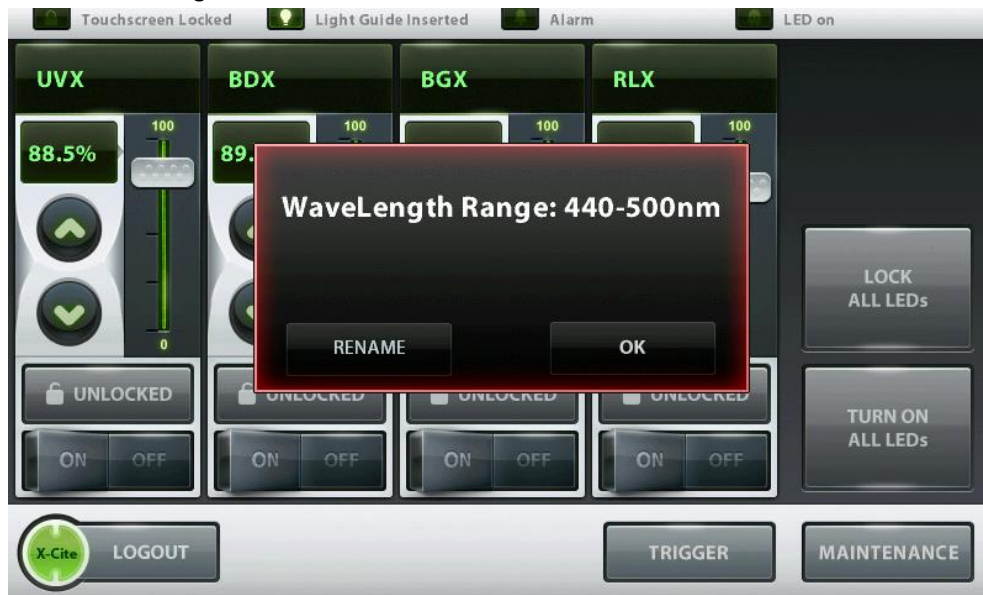

Each LED module section has Unlocked (grey), Locked (green), OFF (grey), and ON (green) features. The Unlock/Lock pads, unlock or lock that individual LED module section. In lock mode all settings (coarse and fine intensity, percentage window and wavelength window) for that LED module are locked and cannot be changed.

Each LED module section has a coarse intensity adjustment slider and fine intensity adjustment "UP"▲ and "DOWN"▼ pads. The fine intensity adjustment arrows allow intensity adjustments from 5% to 100% in 0.1% increments. A numerical value can be entered by clicking on the % value to access the popup Edit Entry window. Enter a number and press OK. The intensity will now be changed.

The main screen has a global “**LOCK ALL LEDS**”, this button sets all the individual lock buttons to locked.

The main screen has a global “**TURN OFF/ON ALL LEDS**” pad which will disable and enable all LEDs at once.

The main screen displays Icons for, “Light Guide Inserted”, “Alarms” and “LED on”.

Click on the “**LOGOUT**” button to close the GUI Control Panel. All previous data entered will be saved upon next start up.

6.2 Set LED Triggers Screen



Figure 13 LED Trigger Screen (GUI)

The screen displays individual Trigger window sections for each LED module (e.g.: UVX, BDX, BGX and RLX). Click the top of a wavelength section to open that selected window.

In each window section the user can change the trigger designation to OFF, Internal (indicated by time units), External and Global. Press the “**CHANGE TRIGGER**” pad to select a trigger designation. Each LED module can only have one trigger designation.

The triggers are described below:

- A. The default trigger designation is set to OFF in order to allow control of the system from the main LED screen.

- B. When in high speed triggering mode the sync signal is an acknowledgement of a received command.
- C. When the trigger is set to External: the system will accept an external signal control to the selected LEDs. (refer to [Table 8](#)).
- D. When the trigger is set to GLOBAL, the system will accept a trigger signal through a single pin to control all LEDs that are set to GLOBAL. (refer to [Table 8](#)).



Note: *When selecting External or Global trigger the LEDs will not turn on until a trigger signal is present. The LEDs will accumulate hours while in External or Global trigger mode. To prevent unnecessary hour accumulation on LED modules while using the XLED1 system, users are advised to enable these XLED1 advanced triggering modes only during the window of time that will be used for such purposes. Subsequent to using the advanced triggering capabilities of the XLED1 system, the user should ensure that triggering is “OFF” in the trigger configuration screen.*

- E. When the trigger is set to Internal, (as indicated by “zeroes”) the user can define the “DELAY TIME”, “ON TIME”, ‘OFF TIME” AND ‘SYNC OUT TIME”. To change the numerical values of the times, click the up and down arrows or click the box next to the value to open up a popup Edit Entry window where you can enter the desired numeric value. To change the time units click the “CHANGE UNITS” pad and select a time value unit of microseconds, milliseconds or seconds.



Note: *When changing the time value units; selecting a value unit will change all 4 times associated with that LED to that unit. Each LED module can only have one time domain unit.*

- F. Once all the timing parameters have been defined for each LED module, click the “REPEAT LOOP” pad to ON (green) for automatic looping. For manual use or test purposes ensure the “REPEAT LOOP” pad is OFF and use the “START” and “STOP” pads to start and stop the process.



Note: *Ensure that the trigger is set to OFF in order to control LEDs from the main screen.*

- G. A trigger graph can be viewed (refer to [section 7.5](#)) for each LED module by clicking on the “VIEW TRIGGER GRAPH”.
- H. Once the trigger is set-up for EXTERNAL or GLOBAL, go back to the MAIN LED screen (**see below**) and push the TRIGGER Button below the triggered LED. For the LED to turn on after a trigger voltage is received, this button must be depressed.



ADDITIONAL TRIGGER SET-UP INSTRUCTIONS

Live Cell Configuration owners should refer to [section 8.0](#) for Live Cell Mode Instructions

- a. In internal triggering mode, the LEDs in the same time domain (a time domain is either seconds, milliseconds or microseconds) will be automatically synchronized. The LED period (determined by adding the Delay Time, On Time and Off Time) will be adjusted to the longest period selected. In the example shown in graph LED A below, the total period is 6 seconds. Then as shown in graph LED B below, the period defined by the user is 4 seconds. In this case, an additional 2 seconds will be added to adjust the time period to 6 seconds to match that of LED A.

- b. In internal triggering mode, if the period of one LED is less than 2 times the period of another LED in the same time domain, the system will generate additional cycles to compensate for the longest period in the time domain. Example: In graph LED A below the period is 6 seconds. In graph LED C the period specified was 2 seconds. The software will automatically create three cycles to fill in the same period as LED A. If this is not desired, the off time for LED C needs to be extended so that the LED C total period will be equal to that of LED A. In this example change the off time from 0 seconds to 4 seconds in order for the total period time to equal to 6 seconds.

NOTE: The additional pulses can only be added up to a maximum which depends on the number of channels being used in the same time domain. Typically only 12 sub pulses can be generated, if more are needed try using different time domains to achieve the desired results.

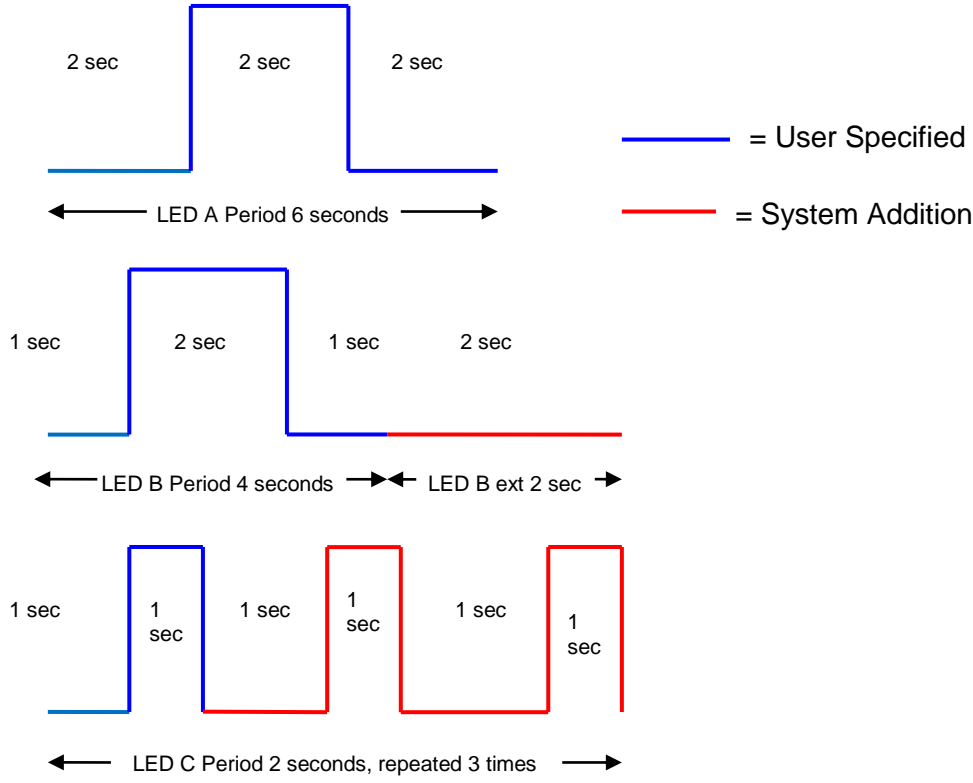

6.3 Trigger Graphs Screen

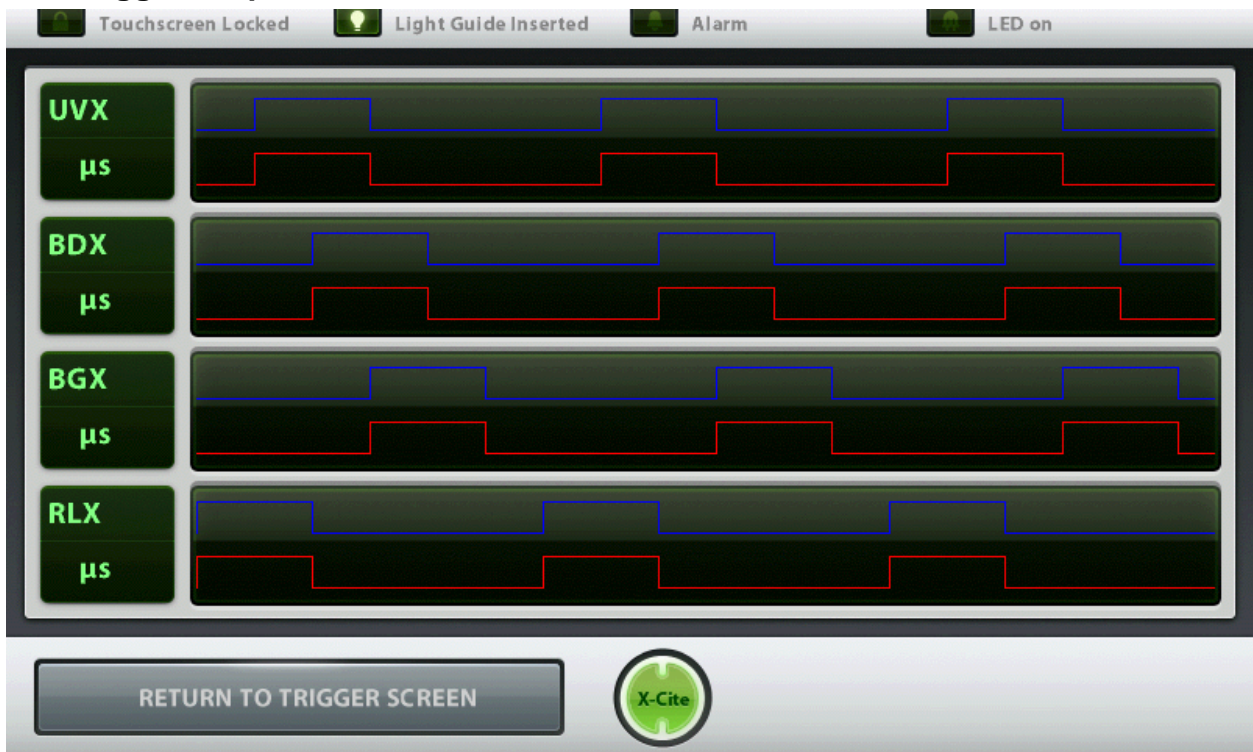

Figure 14 Trigger Graphs Screen (GUI)

The trigger graph screen shows all 4 LED Modules as separate graphical representations of the triggering patterns assigned from the Set LED Trigger screen.

To return to the LED Trigger Screen touch **“Return to Trigger Screen”**.

6.4 Maintenance Screen



Figure 15 Maintenance Screen (GUI)

The Maintenance screen gives an overview of the location of the 4 individual LED modules, drivers and dichroics.

Click on any one of the green lit Modules to retrieve the pop-up window showing the selected Modules present attributes.

- λ : Displays LED Module wavelength range in nm.
- λ /FWHM (Full Width Half Max): e.g. depicts LED peak wavelength +/-FWHM, the useful bandwidth of the LED.
- Type: Identifies the LED Module as either Standard Power or High Power version which is determined by the LED type.
- Current: Displays the current working temperature of the LED module in °C.
- Cutoff Temp: indicates the maximum specified working temperature of the LED module in °C.
- LED Used: Records the current accumulated LED module illumination hours.
- Serial Number: Displays the serial number of the LED module.
- Mfg ON: Displays the manufacturing date of the LED module. The remaining touch pads are for navigating to the various screens.

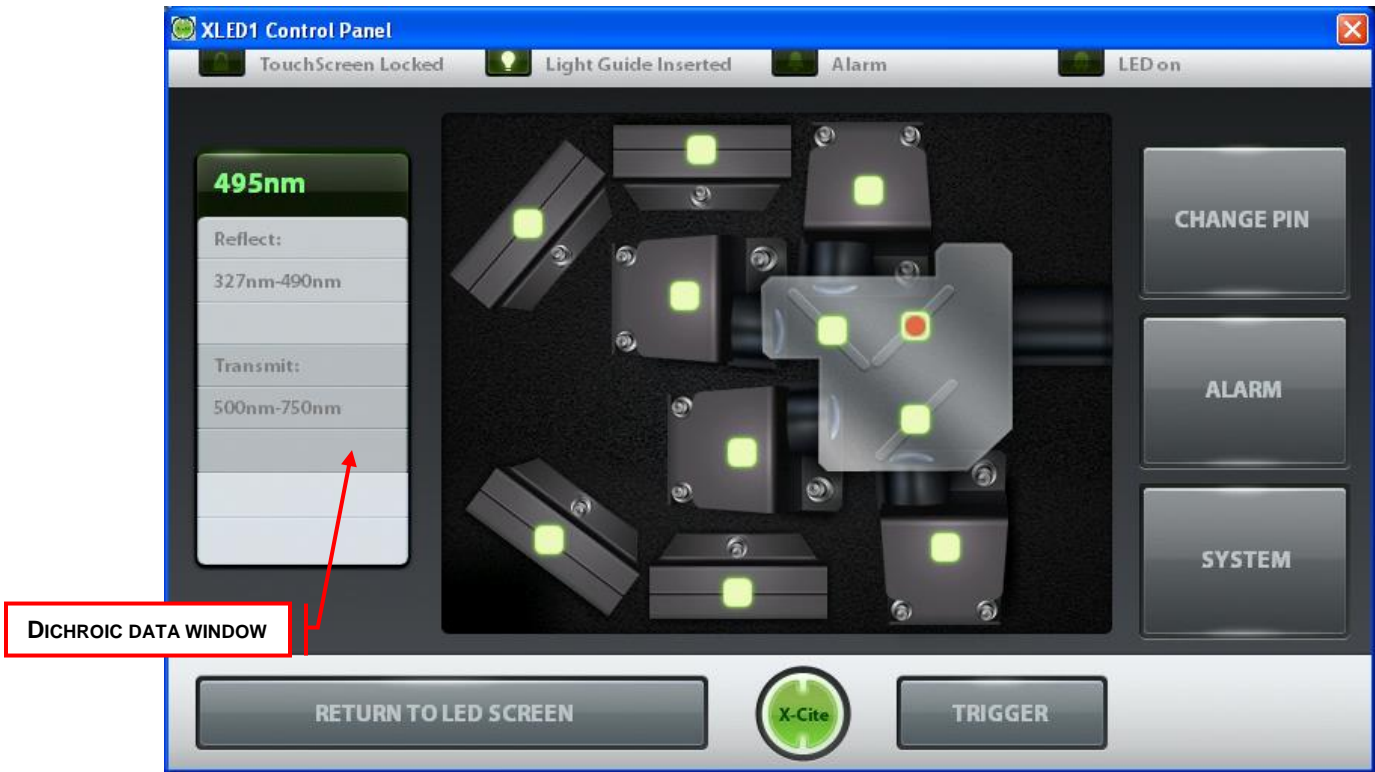

Figure 17 Maintenance Screen (Dichroic Data) (GUI)

When clicking on a Dichroic module icon, a Dichroic data window will display the following attributes:

- Edge: specified in nm (top tab of the window).
- Reflect: the wavelength range that the Dichroic will reflect, specified in nm.
- Transmit: the wavelength range the Dichroic will transmit, specified in nm.

When changing a Dichroic, the Edge value must be entered into the system. To change the Edge value, click on the Dichroic icon to see the pop-up window, click on the top tab of the Dichroic information window and a pop-up Dichroic Selection screen will appear. Select the new edge value from the drop down menu and click OK to return to the maintenance screen. The Reflect and Transmit values will be automatically populated.

If the new Dichroic is not listed in the drop down menu, refer to Section 6.5 to obtain the Edge Wavelength, Low Reflect, High Reflect, Low Pass and High Pass numbers.

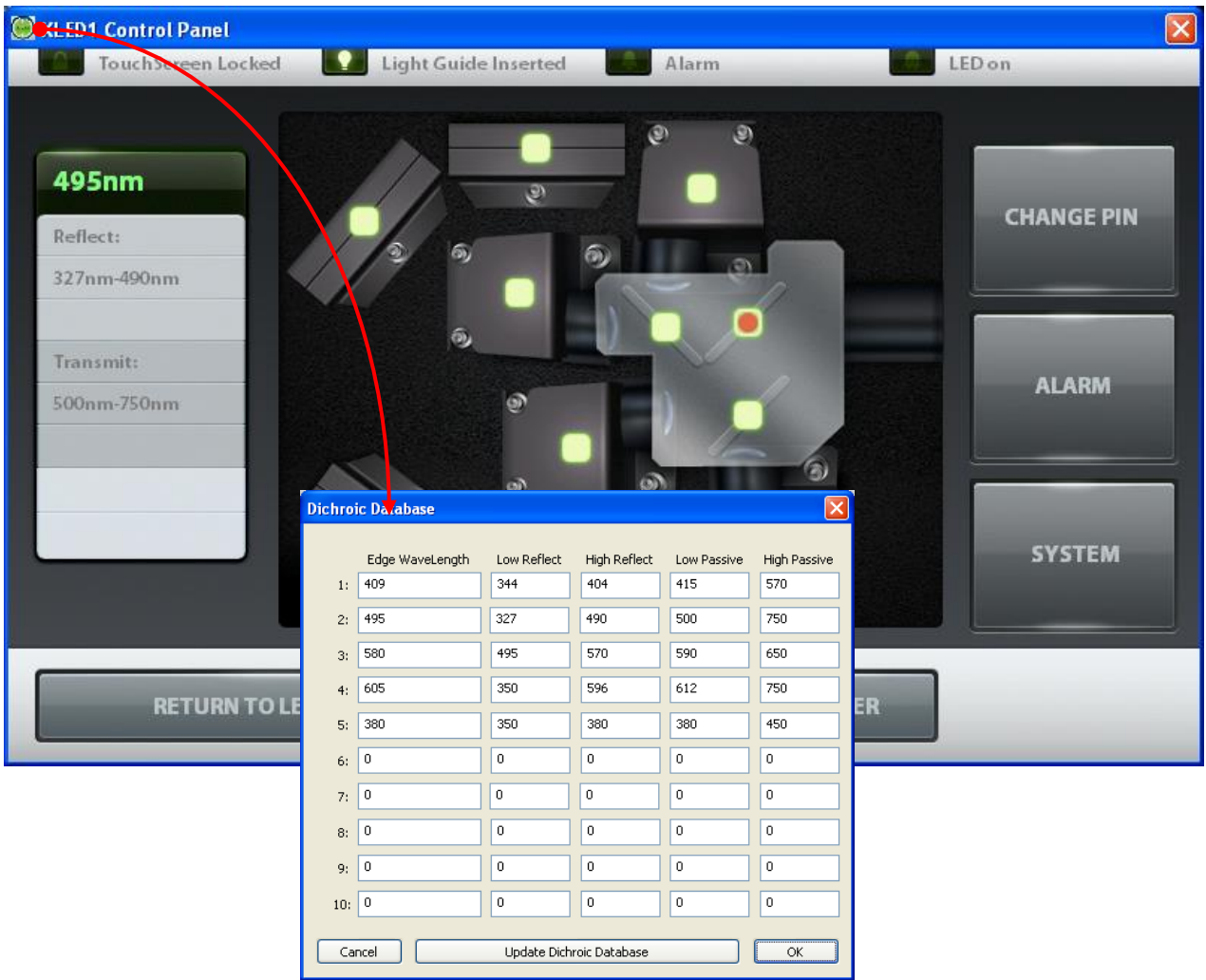

Figure 18 Dichroic Database (GUI)

Click on the green X-Cite® Icon located on the top left corner of the maintenance screen and click on Dichroic Database. A Dichroic Database pop-up window will appear. Fill in the number obtained from the list below (Section 6.5) click Update Dichroic Database to save new entries. Refer to [Figure 18](#).



Note: Refer to [section 4.2](#) for LED Module and Driver replacement

6.5 Dichroic Values

Dichroic/Edge wavelength	Low Reflect	High Reflect	Low Pass	High Pass
409	325	404	415	530
458	350	450	467	950
495	350	488	502	750
538	350	528	547	950
605	350	596	612	750
Special order				
380	350	375	385	450
416	360	407	425	575
660	350	654	669	750

6.6 Alarm Information

Alarms	Description	Severity	Recoverable
Max Temp Exceeded	Max. LED module Over Temperature Protection	Critical	Yes
Min Temp Exceeded	Min. LED module Under Temperature Protection	Major	Yes
LED Module Fail	LED Module Failure	Critical	No
Light Guide Not Present	Light Guide Removed	Major	Yes
Comms Error	Internal Communication Error	Critical	No
Watchdog Timeout	Watchdog Tripped	Critical	No
NVM Fail	Non Volatile Memory Fail	Critical	No
System Performance	System Performance	Major	Yes

Table 2 Alarm Codes (GUI)



Figure 19 Alarm Code Screen (GUI)

Error Pop-up Screens Descriptions

Error Window	Error Description	Screen Location
"Light Guide not inserted"	Request to turn on LED could not be completed due to the Light Guide not being fully inserted	All screens
"Enter Delay or Off Time"	Request to start Pulse Generator cycle could not be completed due to missing delay or off time entry	Trigger screen
"To change units or trigger, LED must be off"	Requested settings change was not completed as the LED was on	Trigger screen
"Alarm Active on LED, Proceed to maintenance screen "	Request to turn on an LED could not be completed due to an active alarm	Main screen
"Dichroic not found"	Wrong Dichroic number entered	Maintenance screen
"Function only available on XLED1"	Pop-up error window appears when trying to perform a function which is not available via the GUI	Pop-up error window on all screens

Table 3 Error Pop-up Screen Descriptions (GUI)

The 8 visual alarm indicators on the Alarm Code Screen (refer to Figure 19) are indicators only and do not function as alarm clearing buttons/pads.

The LED System is designed to detect certain conditions that may affect safe or proper functioning. These conditions are categorized as one of two “alarm types” according to the danger they pose to the operator, system or experiment:

1. Critical – Do not continue process, alarm shall not be clearable until “Alarm Condition” is corrected. Contact:
<http://www.excelitas.com/Pages/Support/Service-Request-Form.aspx>
2. Major – operation may continue, but depending on specific alarm condition, functionality of unit may be limited or impossible. Contact:
<http://www.excelitas.com/Pages/Support/Service-Request-Form.aspx>

The Alarm Information screen displays icons for the alarm codes which will light up when triggered.

6.7 Clearing alarms

The 8 visual alarm indicators on the Alarm Code Screen (refer to Figure 19) are indicators only and do not functional as alarm clearing buttons/pads.

The GUI system does not provide an audible alarm to alert the operator of “Light Guide not inserted” condition.

The following visual alarms will clear automatically when the problem subsides:

- Max Temp Exceeded, Min Temp Under Limit, LED Module Fail, Light Guide Not Present.

6.8 System Information



Figure 20 System Information (GUI)

System Screen - Shows an overview of the complete system (GUI Control Panel and XLED1):

Errors Window:

- Displays error description sent by the XLED1 detected during the power-on-self-test (POST) and errors detected during operation. Refer to [Table 7](#) for error window descriptions.

Software Versions Window:

- Displays the current software versions installed in the XLED1/Pulse Generator/ GUI Control Panel.

Serial Number Window:

- Displays the serial number of the XLED1.

LCD Settings Window:

- Volume, Brightness and Timeout sliders are not functional when using the GUI. All sliders will function and change the values if connected to the XLED1 Touch Screen Controller.

POWER ON SELF TEST:

- Disabled in GUI Control Panel

ALIGN TOUCH SCREEN:

- Disabled in GUI Control Panel

Error Window	Error Description
"LED <wavelength> over temperature"	LED module is above allowable working temperature
"LED <wavelength> current alarm"***	LED module is off when system is told it is on (only valid when not in trigger mode) or LED module is on when system is told it is off (only valid when NOT in trigger mode)
"LED <wavelength> under temperature"	LED module is below allowable working temperature
"LED<wavelength> NVM error"	LED module memory is experiencing problems
"LED <wavelength> ADC error"	Internal error
"LED <wavelength> Type Mismatch"	LED module/LED driver types are mismatched.

Table 4 Error Window Descriptions (GUI)



***Note: The alarm will not be triggered if an LED fails when the intensity is set to under 10%. To check if an LED has failed in this case, simply move the intensity slider to 100% to check if it is functional **(WITH CAUTION)**

7. Operating the Optional Touch Screen Controller



Caution: Only connect the LGDI Touch Screen Controller to the XLED1 via rear port as per [Figure 2](#).

The Touch Screen Controller is a touch screen interface to control the XLED1.

Screen Sitemap:

- Log In (refer to [section 7.1](#))
- Main LED Screen (refer to [section 7.2](#))
- Edit LED Name (refer to [section 7.3](#))
- Set LED Triggers (refer to [section 7.4](#))
- Trigger Graphs (refer to [section 7.5](#))
- Maintenance (refer to [section 7.6](#))
- Alarm Information (refer to [section 7.7](#))
- System Information (refer to [section 7.9](#))

Note: all screens have a top bar indicator:

- **Touch Screen Locked:** Indicates that all screens are locked, refer to [section 7.2](#) for detailed instructions.
- **Light Guide Inserted:** Illuminates when the Light Guide is properly inserted.
- **Alarm:** Indicates a system alarm, user should navigate to the Alarm Screen to determine the source of the alarm (refer to [section 7.7](#)).
- **LED on:** Illuminated when any LED Module is on.

7.1 Log-In Screen

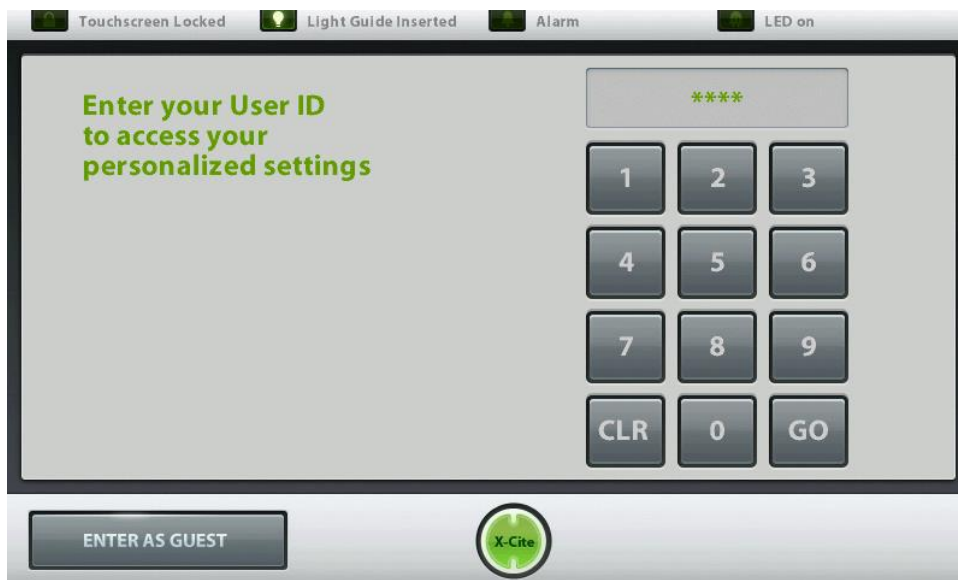

Figure 21 Log-In Screen (Touch Screen Controller)

The XLED1 will automatically login as user 5 if embedded software version is 1.5 or later. The login screen is only available by clicking logout on the main LED screen. |

Maximum Users – 5 User ID Numbers. User ID numbers must be 4 digits. The system ships with qty.5 default ID log-in numbers **1234 / 2234 / 3234 / 4234 / 5234**.

Note: User ID 5 settings will be default on XLED1 power up, if the XLED1 Touch Screen Controller is disconnected during the next power up.

Enter the default ID 4 digit log-in number to access the system. The XLED1 will remain non-functional if the incorrect user ID is entered.

Upon entering User ID press '**GO**' to navigate through all the Touch Screen Controller screens and control the XLED1.

If logged in as a 'Guest' all data will **not** be saved after completion of session.



Note: Prior to S/W version 1.5, *Ensure that users **log-out** of the Touch Screen Controller before powering down or all entered data from the latest session will not be saved. (refer to [section 7.2](#)). The system is defaulted **NOT** to save any data when logged in as 'Guest' regardless of logging out or not. If version 1.5 or later, the settings will be saved 5 minutes after the last setting change,*

If desired the user can create a personal PIN number. Navigate to the Maintenance screen and press the '**CHANGE PIN**' pad.

Enter new PIN number (max 4 digits) and press '**GO**'. Re-enter the new PIN number to verify and press '**GO**'.

A pop-up message will appear if the wrong PIN number is re-entered. Re-enter the correct new PIN number and press '**GO**'.

7.2 Main LED Screen



Figure 22 Main LED Screen (Touch Screen Controller)

The main screen displays a section for each LED module, (e.g: UVX, BDX, BGX and RLX), these can be renamed to desired fluorophores (refer to [section 7.3](#)). Tap on the desired wavelength name/number to access the Edit LED screen. Click on the desired wavelength name to view the wavelength range or to rename the LED. Enter a name or number and press OK. The display will now be changed.

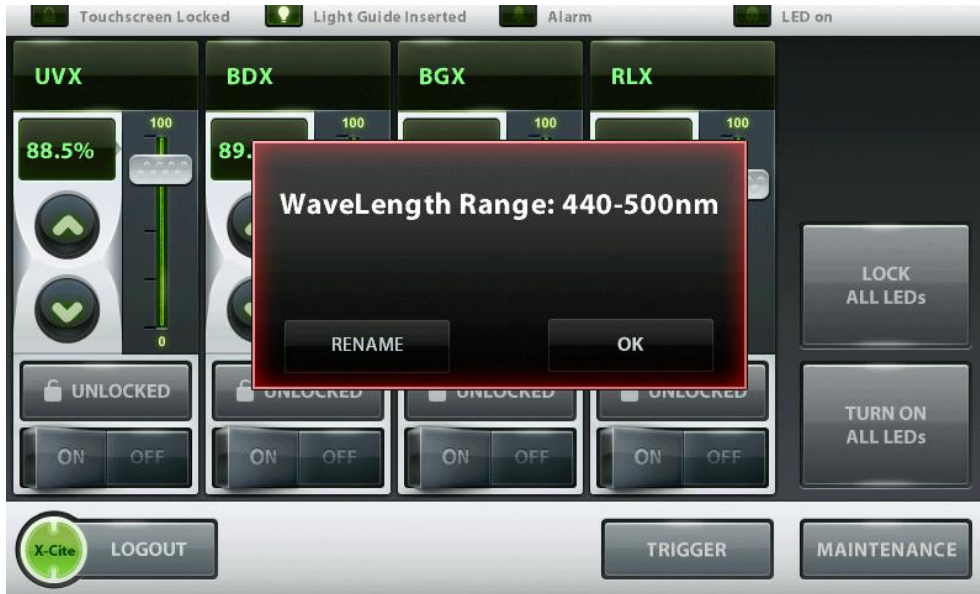

Each LED module section has Unlocked (grey), Locked (green), OFF (grey), and ON (green) features. The Unlock/Lock pads, unlock or lock that individual LED module section. In lock mode all settings (coarse and fine intensity, percentage window and wavelength window) for that LED module are locked and cannot be changed.

Each LED module section has a coarse intensity adjustment slider and fine intensity adjustment "UP"▲ and "DOWN"▼ pads. The fine intensity adjustment arrows allow intensity adjustments from 5% to 100% in 0.1% increments. A numerical value can be entered by tapping on the % value, which opens up a numerical keypad window.

The main screen has a global "LOCK ALL LEDS", this button sets all the individual lock buttons to locked.

The main screen has a global "TURN OFF/ON ALL LEDS" pad which will disable and enable all LEDs at once.

The main screen displays icons for “Touch Screen Locked”, “Light Guide Inserted”, “Alarms” and “LED on”.

It is very important to use the “**LOGOUT**” touch pad before powering down the system. Failure to logout before powering down will result in loss of the present settings, the system will then default to previous settings upon the next start-up.

Ability to navigate to the “**TRIGGER**” screen and the “**MAINTENANCE**” screen .



Note: See notes in box identical to this one. Ensure that users **log-out** of the Touch Screen Controller before powering down or all entered data from the latest session will not be saved. (refer to [section 7.2](#)). The system is defaulted **NOT** to save any data when logged in as ‘Guest’ regardless of logging out or not.

7.3 Edit LED Name Screen

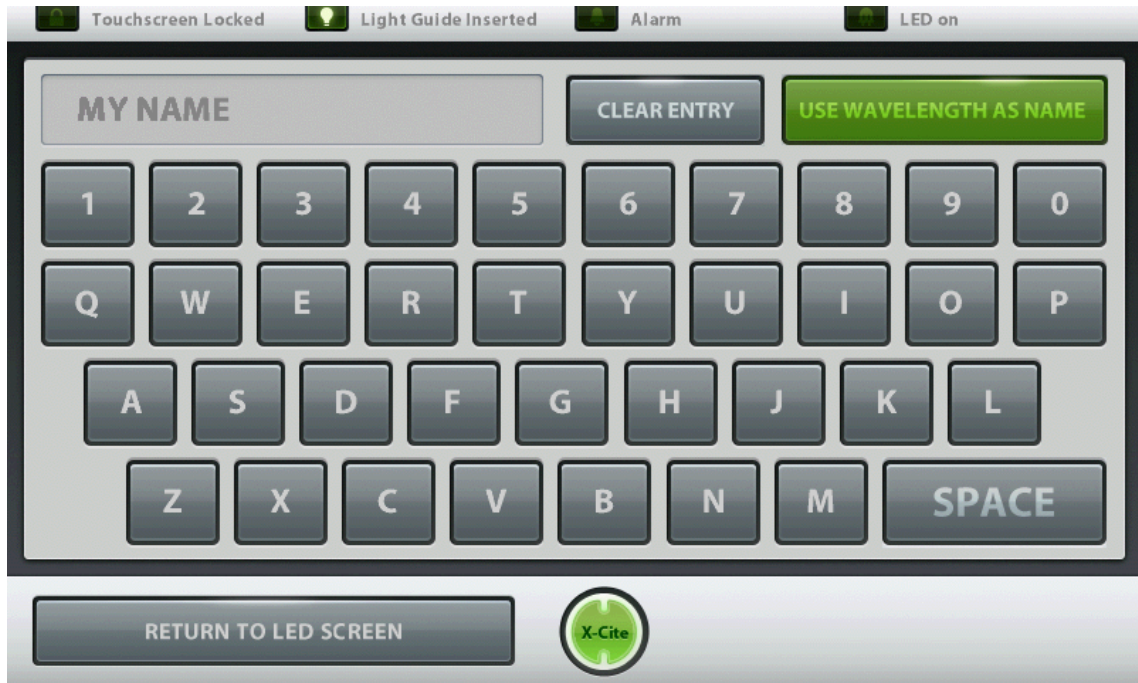

Figure 23 LED Name Edit Screen (Touch Screen Controller)

The Edit screen displays a touch key pad to enable the user to rename the LED modules if desired, e.g. – DAPI, FITC, TRITC etc. Once the name has been entered press “**RETURN TO LED SCREEN**” to go back to the Main LED Screen.

The name is limited to 8 characters.

To display the centre wavelength as the wavelength name, press the “**USE WAVELENGTH AS NAME**” pad.

7.4 Set LED Triggers Screen



Figure 24 LED Trigger Screen (Touch Screen Controller)

Note: Important, when the XLED1 is in live cell mode, the internal trigger is occupied performing that mode. This trigger screen is ineffective when operating in live cell mode. If trigger mode is required, turn off live cell mode first. Refer to section 8 for more information.

The screen displays individual Trigger window sections for each LED module (e.g: UVX, BDX, BGX and RLX). Touch the top of a wavelength section to open that selected window.

In each window section the user can change the trigger designation to OFF, Internal (indicated by time units), External and Global. Press the “**CHANGE TRIGGER**” pad to select a trigger designation. Each LED module can only have one trigger designation.

The triggers are described below:

- A. The default trigger designation is set to OFF in order to allow control of the system from the main LED screen.
- B. When in high speed triggering mode the sync signal is an acknowledgement of a received command.
- C. When the trigger is set to External: the system will accept an external signal control to the selected LEDs. The LED must still be turned on in the main screen, for the external trigger to be able to turn on the LED. Refer to [Table 8](#)

- D. When the trigger is set to GLOBAL, the system will accept a trigger signal through a single pin to control all LEDs that are set to GLOBAL. The LED must still be turned on in the main screen, for the external trigger to be able to turn on the LED. Refer to [Table 8](#)



Note: When selecting External or Global trigger the LEDs will not turn on until a trigger signal is present. The LEDs will accumulate hours while in External or Global trigger mode. To prevent unnecessary hour accumulation on LED modules while using the XLED1 system, users are advised to enable these XLED1 advanced triggering modes only during the window of time that will be used for such purposes. Subsequent to using the advanced triggering capabilities of the XLED1 system, the user should ensure that triggering is “OFF” in the trigger configuration screen.

- E. When the trigger is set to Internal, (as indicated by “zeroes”) the user can define the “DELAY TIME”, “ON TIME”, ‘OFF TIME” AND ‘SYNC OUT TIME”. To change the numerical values of the times, press the up and down arrows or touch the box next to the value to open up a key pad screen where you can enter the desired numeric value. To change the time units press the “CHANGE UNITS” pad and select a time value unit of microseconds, milliseconds or seconds.



Note: When changing the time value units; selecting a value unit will change all 4 times associated with that LED to that unit. Each LED module can only have one time domain unit.

- F. Once all the timing parameters have been defined for each LED module, press the “REPEAT LOOP” pad to ON (green) for automatic looping. For manual use or test purposes ensure the “REPEAT LOOP” pad is OFF and use the “START” and “STOP” pads to start and stop the process.



Note: Ensure that the trigger is set to OFF in order to control LEDs from the main screen.

- G. A trigger graph can be viewed (refer to [section 7.5](#)) for each LED module by touching the “VIEW TRIGGER GRAPH”.
- H. Once the trigger is set-up for EXTERNAL or GLOBAL, go back to the MAIN LED screen (**see below**) and push the TRIGGER Button below the triggered LED. For the LED to turn on after a trigger voltage is received, this button must be depressed.



ADDITIONAL TRIGGER SET-UP INSTRUCTIONS

Live Cell Configuration owners should refer to [section 8.0](#) for Live Cell Mode Instructions

- a. In internal triggering mode, the LEDs in the same time domain (a time domain is either in seconds, milliseconds or microseconds) will be automatically synchronized. The LED period (determined by adding the Delay Time, On Time and Off Time) will be adjusted to the longest period selected. In the example shown in graph LED A below, the total period is 6 seconds. Then as shown in graph LED B below, the period defined by the user is 4 seconds. In this case, an additional 2 seconds will be added to adjust the time period to 6 seconds to match that of LED A.

- b. In internal triggering mode, if the period of one LED is less than 2 times the period of another LED in the same time domain, the system will generate additional cycles to compensate for the longest period in the time domain. Example: In graph LED A below the period is 6 seconds. In graph LED C the period specified was 2 seconds. The software will automatically create three cycles to fill in the same period as LED A. If this is not desired, the off time for LED C needs to be extended so that the LED C total period will be equal to that of LED A. In this example change the off time from 0 seconds to 4 seconds in order for the total period time to equal to 6 seconds.

NOTE: The additional pulses can only be added up to a maximum which depends on the number of channels being used in the same time domain. Typically only 12 sub pulses can be generated, if more are needed try using different time domains to achieve the desired results.

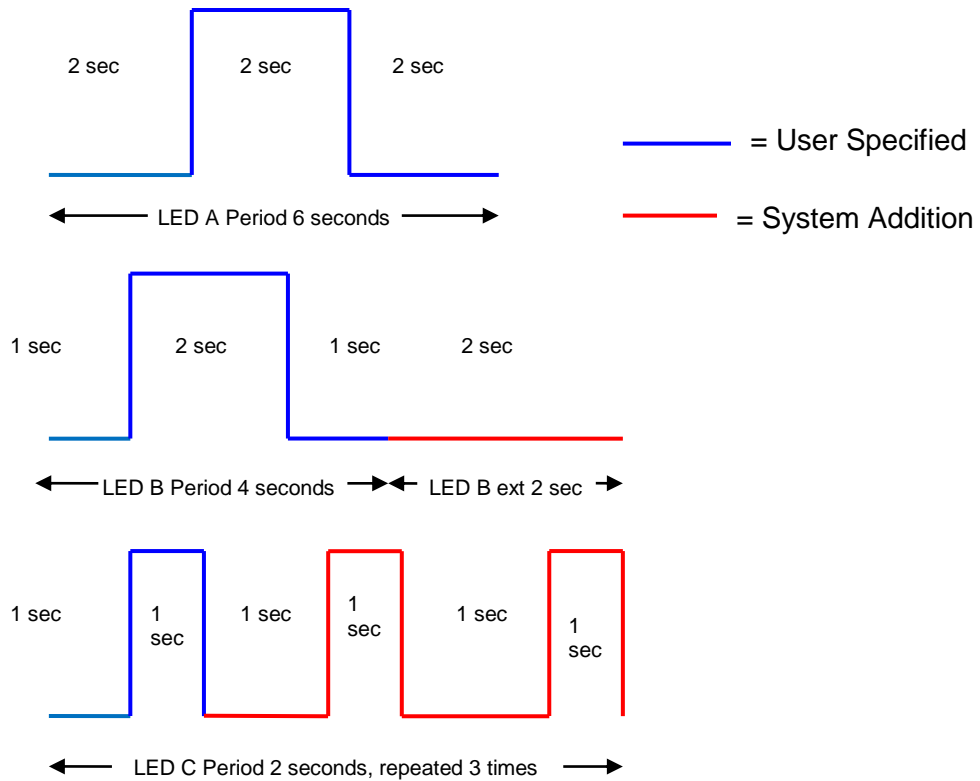

7.5 Trigger Graphs Screen



Figure 25 Trigger Graphs Screen (Touch Screen Controller)

The trigger graph screen shows all 4 LED Modules as separate graphical representations of the triggering patterns assigned from the Set LED Trigger screen.

To return to the LED Trigger Screen touch **“Return to Trigger Screen”**.

7.6 Maintenance Screen

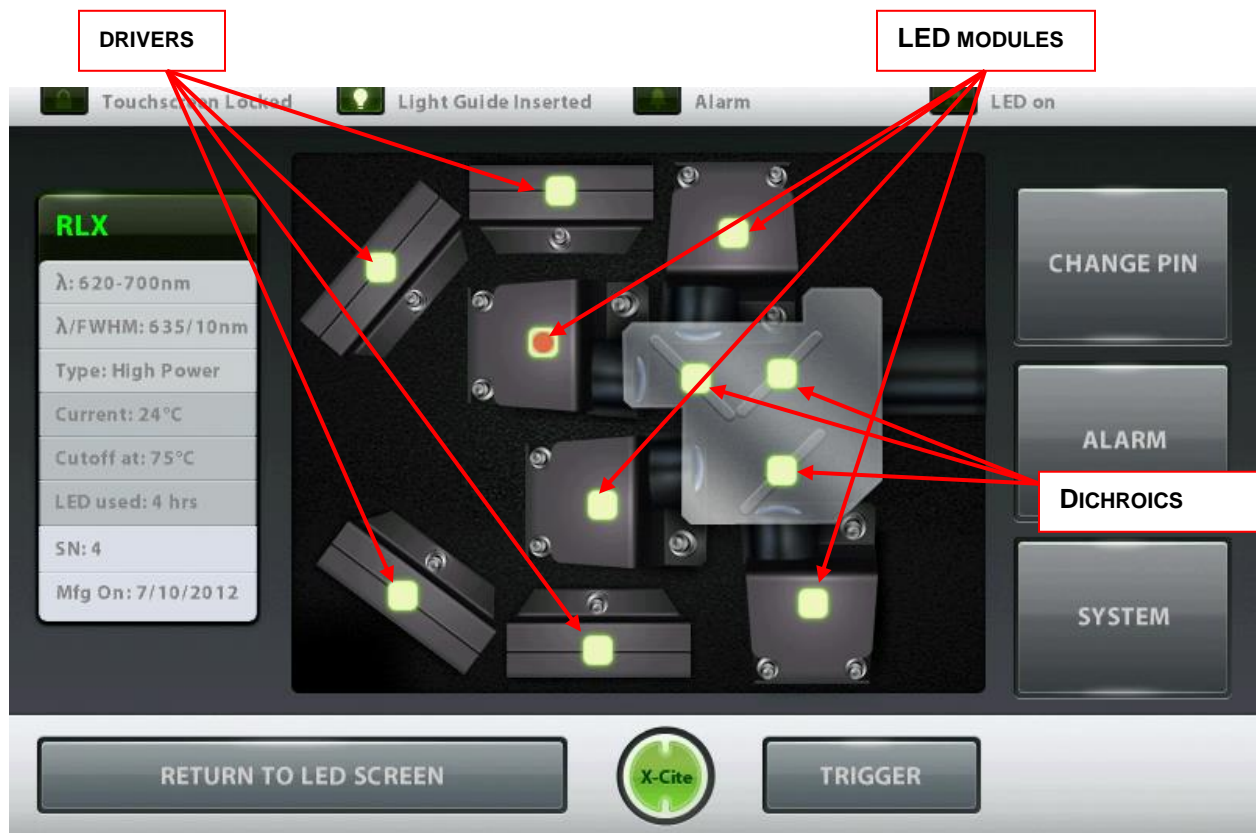

Figure 26 Maintenance Screen (Touch Screen Controller)

The maintenance screen gives an overview of the locations of the 4 individual LED Modules, Drivers and Dichroics.

Touch any one of the green lit Modules to retrieve the pop-up window showing the selected Modules present attributes.

- λ : Displays LED Module wavelength range in nm.
- λ /FWHM (Full Width Half Max): e.g. depicts LED peak wavelength +/-FWHM, the useful bandwidth of the LED.
- Type: Identifies the LED Module as either Standard Power or High Power version which is determined by the LED type.
- Current: displays the current working temperature of the LED module in °C.
- Cutoff Temp: indicates the maximum specified working temperature of the LED module in °C.
- LED Used: Records the current accumulated LED module illumination hours.
- Serial Number: displays the serial number of the LED module.
- Mfg ON: displays the manufacturing date of the LED module. The remaining touch pads are for navigating to the various screens.



Figure 27 Maintenance Screen (Dichroic Data) (Touch Screen Controller)

When touching a Dichroic icon, a Dichroic pop-up window will display the following attributes:

- Edge: specified in nm (top tab of the window).
- Reflect: the wavelength range that the Dichroic will reflect, specified in nm.
- Transmit: the wavelength range the Dichroic will transmit, specified in nm.

When changing a Dichroic, the Edge value must be manually entered into the system. To change the Edge value, touch on the Dichroic icon to see the pop-up window, touch the top tab of the Dichroic information window and an edit screen will appear. Type in the new Edge value and press “GO” to return to the maintenance screen. Refer to [section 11](#) for Dichroic replacement.

For new Dichroics, the reflect and transmit values will not be automatically updated, refer to Section 6.5 for these values. The data cannot be entered into the Touch Screen Controller manually. The system will light up the new Dichroic in red. This means the data is not available but the system will still be functional. To update the values, use the GUI on your PC, refer to [sections 0 to 0](#).



Note: Refer to [section 4.2](#) for LED Module and Driver replacement

7.7 Alarm Information

Alarms	Description	Severity	Recoverable
Max Temp Exceeded	Max. LED Module Over Temperature Protection	Critical	Yes
Min Temp Exceeded	Min. LED Module Under Temperature Protection	Major	Yes
LED Module Fail	LED Module Failure	Critical	No
Light Guide Not Present	Light Guide Removed or not fully inserted	Major	Yes
Comms Error	Internal Communication Error	Critical	No
Watchdog Timeout	Watchdog Tripped	Critical	No
NVM Fail	Non Volatile Memory Fail	Critical	No
System Performance	System Performance	Major	Yes

Table 5 Alarm Codes (Touch Screen Controller)



Figure 28 Alarm Code Screen (Touch Screen Controller)

Error Pop-up Screens Descriptions

Error Window	Error Description	Screen Location
* "Light Guide not inserted"	Request to turn on LED could not be completed due to Light Guide not fully inserted	All screens
"Enter Delay or Off Time"	Request to start Pulse Generator cycle could not be completed due to missing delay or off time entry	Trigger screen
"To change units or trigger, LED must be off "	Requested settings change was not completed as the LED was on	Trigger screen
"User ID is incorrect"	Entered incorrect User ID	Login screen
"Retry or enter as Guest"	Entered incorrect User ID	Login screen
"Number is out of range"	The number value entered is out of range	Number input pad
"Alarm Active on LED, Proceed to maintenance screen "	Request to turn on an LED could not be completed due to an active alarm	Main screen
"Dichroic not found"	Wrong Dichroic number entered	Maintenance screen
"PIN already in use"	If PIN is the same as another user's	During PIN update wizard
"Please choose another"	If PIN is the same as another user's	During PIN update wizard
"PINs do not match!"	If the second PIN does not match the first	During PIN update wizard
"Guest cannot change PIN!"	If change PIN button is pressed and the current user is Guest	Maintenance screen

* **3 audible beeps are only generated when the Touch Screen Controller is connected.**

Table 6 Error Pop-up Screen Descriptions (Touch Screen Controller)

The 8 visual alarm indicators on the Alarm Screen (refer to [Figure 28](#)) are indicators only and do not function as alarm clearing buttons/pads.

The LED System is designed to detect certain conditions that may affect safe or proper functioning. These conditions are categorized as one of two “alarm types” according to the danger they pose to the operator, system or experiment:

1. Critical – Do not continue process, alarm shall not be clearable until “Alarm Condition” is corrected. Contact: <http://www.excelitas.com/Pages/Support/Service-Request-Form.aspx>
2. Major – operation may continue, but depending on specific alarm condition, functionality of unit may be limited or impossible. Contact: <http://www.excelitas.com/Pages/Support/Service-Request-Form.aspx>

The Alarm Information screen displays touch pads for the alarm codes which will light up and generate an audible signal when triggered.

7.8 Clearing alarms

The 8 visual alarm indicators on the Alarm Screen (refer to [Figure 28](#)) are indicators only and do not function as alarm clearing buttons/pads.

The system provides an audible alarm to alert the operator of “Light Guide not inserted” condition only

The audible alarm cannot be silenced and will generate 3 audible beeps only.

The following visual alarms will clear automatically when the problem subsides or is corrected:

- Max Temp Exceeded, Min Temp Under Limit, LED Module Fail, Light Guide Not Present.

7.9 System Information



Figure 29 System Information (Touch Screen Controller)

System Information screen: Shows an overview of the complete system (Touch Screen Controller and XLED1);

Errors Window:

- Displays error description sent by the XLED1 detected during the power-on-self-test (POST) and errors detected during operation. Refer to [Table 7](#) for error window descriptions.

Software Versions Window:

- Displays the current software versions installed in the XLED1/Pulse Generator/ Touch Screen Controller.

Serial Number Window:

- Displays the serial number of the XLED1.

LCD Settings Window:

- This screen allows adjustments to the Volume (alarm), Touch Screen Controller screen Brightness and the Touch Screen Controller screen saver Timeout. Drag the sliders up or down for desired settings.
- To disable the “Timeout” (sleep) mode set slider to “0”.

- The screen will go blank after timeout lapses. Touch the screen anywhere to return to present screen

POWER ON SELF TEST:

- Press to start the Power On Self Test. The system will commence with a Power-On-Self-Test (POST). All outputs will be inactive and all inputs will be unresponsive during the POST cycle. In the event of a POST error, the system will report the error and either allow the user to proceed or halt, depending on the error condition. Refer to [section 7.7](#) for error codes.

ALIGN TOUCH SCREEN:

- Press this pad to calibrate the touch screen accuracy.
- Upon pressing the pad follow the instructions on the screen, there is a timeout of 10 seconds between each test. If time lapses the Touch Screen Controller will return to the “System Information Screen”. Press this pad again to calibrate.

Error Window	Error Description
“LED <wavelength> over temperature”	LED Module is above allowable working temperature
“LED <wavelength> current off alarm”***	LED Module is off when system is told it is on (only valid when not in trigger mode)
“LED <wavelength> under temperature”	LED Module is below allowable working temperature
“LED <wavelength> current on alarm”	LED Module is on when system is told it is off (only valid when NOT in trigger mode)
“LED<wavelength> NVM error”	LED Module memory is experiencing problems
“LED <wavelength> ADC error”	Internal error
“LED <wavelength> Type Mismatch”	LED Module/LED driver types are mismatched

Table 7 Error Window Descriptions (Touch Screen Controller)



***Note: The alarm will not be triggered if an LED fails when the intensity is set to under 10%. To check if an LED has failed in this case, simply move the intensity slider to 100% to check if it is functional **(WITH CAUTION)**

8. Live Cell Mode (on Live Cell Configuration units)

Live Cell Mode is a feature embedded in XLED1 Live Cell Configuration units (includes modules BLX, BDX, BGX and GYX). This feature allows any enabled LEDs (together or individually) to switch between pulsed and continuous mode of operation through the LED ON/OFF button on the front of the unit.

NOTE: It is NOT recommended to have both the touch screen controller and GUI connected to the XLED1 at the same time.

8.1 Enabling Live Cell Mode

Hold down the LED ON/OFF button for at least 5 seconds (until light guide indicator light turns orange).

Once enabled, pressing the LED ON/OFF button will cause all 4 LEDs to turn on at 100% power and pulse at the default duty cycle of 50% with a period of 2ms (i.e., 1ms ON, 1ms OFF). To turn off the LEDs, briefly press and release the LED ON/OFF button.

NOTE: The Live Cell Mode is essentially an internal trigger, and the control panel will appear as though a trigger is ON. Choosing the LEDs that are enabled along with their intensities can be done through the touch screen controller or the GUI. To ensure that an LED is disabled upon pressing the LIVE CELL MODE button on the front of the unit, the intensity of the LED must be set to zero on the slider in the control panel.

If LEDs are turned on through the controller or GUI, only those LEDs that are ON will pulse at the default duty cycle of 1ms, at the intensity set on the LED slider. To disable Live Cell Mode the front panel LED ON/OFF button must be depressed until Light Guide indicator light turns green (hold on/off button down for at least 5 seconds).



8.2 Changing duty cycle in Live Cell Mode

The duty cycle may be changed using the XLED1 touch screen controller OR the GUI but NOT both and NOT while the LEDs are on.

The Trigger MUST be stopped in the TRIGGER control screen before changing duty cycle

Using XLED1 touch screen controller:

- 8.2.1.1 Once triggers are stopped, make the change required to the pulse duration (by adjusting ON time and OFF time).
- 8.2.1.2 To save these setting for future use, the user must use the LOG OUT button.
- 8.2.1.3 When you log in again, and enable Live Cell Mode (through the front panel button), the last saved settings (chosen LEDs, intensity and pulse duration) will be used for pulsing
- 8.2.1.4 NOTE: If it is desired to save the changes when the XLED1 touch screen controller is not connected, login as user number 5. If touch screen controller is plugged in, the last change made (before logging out, settings are only saved on logout) will take effect.

Using the GUI:

- 8.2.1.5 Changes can be made to duty cycle and intensity as described above
- 8.2.1.6 When LIVE CELL mode is enabled, these changed will apply when the LED(s) are turned ON.
- 8.2.1.7 When logging out of the GUI make sure to "SAVE SETTINGS". Note: This option only appears if the XLED1 touch screen controller is not connected.
- 8.2.1.8 When the unit is turned on in the future and live cell mode is enabled, the last trigger screen settings and LED intensities are applied.

9. External Control

9.1 External Trigger Interface

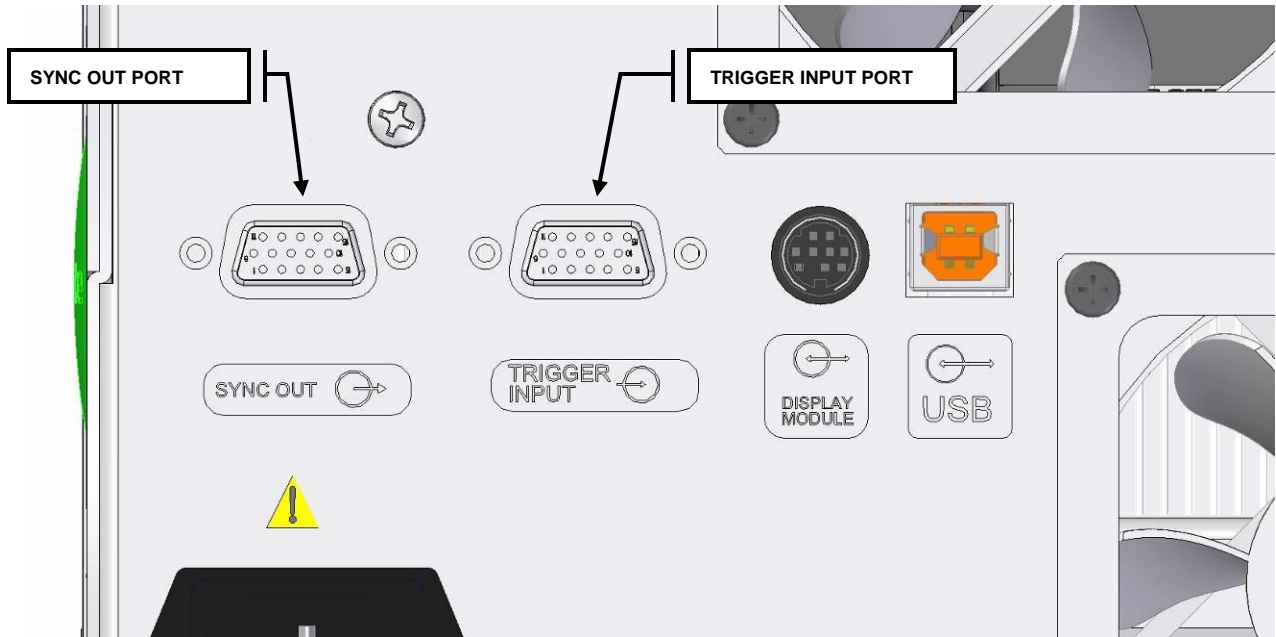

Figure 30 Terminal Block Connectors

The rear panel of the XLED1 (refer to [Figure 30](#)) has two HD15 connectors. One 15-pin HD15 connector for input triggers (refer to [Table 8](#)) and one 15-pin HD15 connector for sync output (refer to [Table 9](#)).

Table 8 External Trigger Pin Assignments

PIN #	Signal name	Description	Location
1	Port 1 trigger +	Port 1 trigger input : High = LED on; Low = LED off	Port 1 (red BNC cable)
2	Port 2 trigger +	Port 2 trigger input : High = LED on; Low = LED off	Port 2 (green BNC cable)
3	Port 3 trigger +	Port 3 trigger input : High = LED on; Low = LED off	Port 3 (blue BNC cable)
4	n/c	Not Connected	
5	n/c	Not Connected	
6	Port 1 trigger -	Ground	Port 1 (red BNC cable)
7	Port 2 trigger -	Ground	Port 2 (green BNC cable)
8	Port 3 trigger -	Ground	Port 3 (blue BNC cable)
9	n/c	Not Connected	
10	n/c	Not Connected	
11	Port 4/Global trigger -	Ground	Port 4 (white+black BNC cable)
12	n/c	Not Connected	
13	Port 4 trigger +	Port 4 trigger input : High = LED on; Low = LED off	Port 4 (white BNC cable)
14	Global trigger +	Global trigger input : High = LED on; Low = LED off	Global (black BNC cable)
15	n/c	Not Connected	

Table 9 External Sync Out Pin Assignments (OUTPUT 5.5V, 8mA max)

PIN #	Signal name	Description	Location
1	Port 1 sync +	Port 1 Sync out : High = LED on; Low = LED off	Port 1 (red BNC cable)
2	Port 2 sync +	Port 2 Sync out : High = LED on; Low = LED off	Port 2 (green BNC cable)
3	Port 3 sync +	Port 3 Sync out : High = LED on; Low = LED off	Port 3 (blue BNC cable)
4	n/c	Not Connected	
5	n/c	Not Connected	
6	Port 1 sync -	Ground	Port 1 (red BNC cable)
7	Port 2 sync -	Ground	Port 2 (green BNC cable)
8	Port 3 sync -	Ground	Port 3 (blue BNC cable)
9	n/c	Not Connected	
10	n/c	Not Connected	
11	Port 4 sync -	Ground	Port 4 (white BNC cable)
12	n/c	Not Connected	

PIN #	Signal name	Description	Location
13	Port 4 sync +	Port 4 Sync out : High = LED on; Low = LED off	Port 4 (white BNC cable)
14	n/c	Not Connected	
15	n/c	Not Connected	

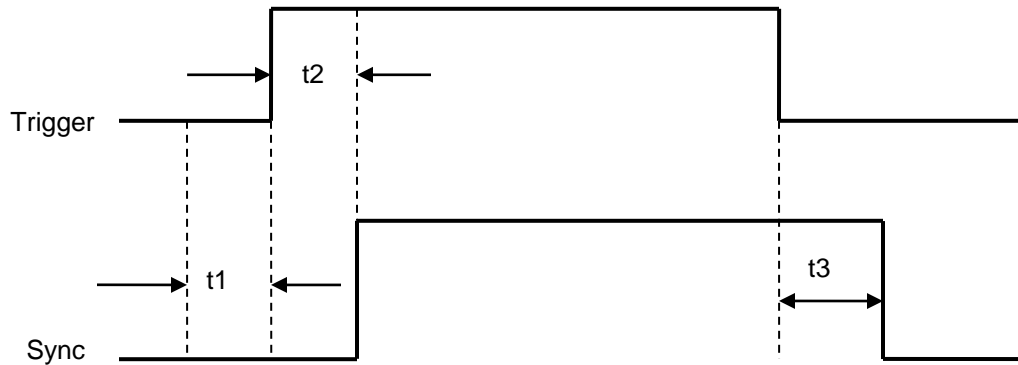

t1 – pre-sync time
t2 – sync delay time
t3 – post-sync time

9.2 Trigger Input/Sync Output Signals Requirements

- Trigger Input Signal Requirements
 - Low-level input : 0 ~ +0.8VDC
 - High-level input: +4.5 ~ +5.5VDC
 - Maximum input current: 6.5mA
- Sync Output Signal Requirements:
 - Low-level output : 0 ~ +0.8VDC
 - High-level output : +4.5 ~ +5.5 VDC
 - Maximum output current: 100uA

9.3 I/O Signal Descriptions

External Trigger Input

- 15V signal applied to **Port 1 trigger +**, this will turn on LED Module 1, when LED Module 1 is in external trigger mode.
- 10V signal applied to **Port 1 trigger +**, this will turn off LED Module 1, when LED Module 1 is in external trigger mode.

¹ LED Module 1 is not necessarily the lowest wavelength installed refer to figures 4, 22, 23 for configurations.

- 5V signal applied to **Port 2 trigger +**, this will turn on LED Module 2, when LED Module 2 is in external trigger mode.
- 0V signal applied to **Port 2 trigger +**, this will turn off LED Module 2, when LED Module 2 is in external trigger mode.
- 5V signal applied to **Port 3 trigger +**, this will turn on LED Module 3, when LED Module 3 is in external trigger mode.
- 0V signal applied to **Port 3 trigger +**, this will turn off LED Module 3, when LED Module 3 is in external trigger mode.
- 5V signal applied to **Port 4 trigger +**, this will turn on LED Module 4, when LED Module 4 is in external trigger mode.
- 0V signal applied to **Port 4 trigger +**, this will turn off LED Module 4, when LED Module 4 is in external trigger mode.
- 5V signal applied to **Global trigger +**, this will turn on all LED Modules which are in global trigger mode.
- 0V signal applied to **Global trigger +**, this will turn off all LED Modules which are in global trigger mode.

External Sync Output

- ²A 5V signal will be produced on **Port 1 sync +**, when LED Module 1 has been triggered.
- ²A 0V signal will be produced on **Port 1 sync +**, when LED Module 1 has not been triggered.
- A 5V signal will be produced on **Port 2 sync +**, when LED Module 2 has been triggered.
- A 0V signal will be produced on **Port 2 sync +**, when LED Module 2 has not been triggered.
- A 5V signal will be produced on **Port 3 sync +**, when LED Module 3 has been triggered.
- A 0V signal will be produced on **Port 3 sync +**, when LED Module 3 has not been triggered.
- A 5V signal will be produced on **Port 4 sync +**, when LED Module 4 has been triggered.
- A 0V signal will be produced on **Port 4 sync +**, when LED Module 4 has not been triggered.

² LED Module 1 is not necessarily the lowest wavelength installed refer to figures 4, 22, 23 for configurations.

10. LED Module and Driver Replacement



CAUTION

To protect the LED Module, Driver and system from electrostatic discharge (ESD) related damage, which can disable the system, cause latent defects or permanent damage, or require repair by service technicians, please take the following ESD prevention steps:

- Ensure the unit is unplugged
- Ensure you are properly grounded, ideally by using an ESD grounding strap attached to an ESD protective surface.

Refer to [section 2.3](#) for principles of ESD and additional ESD precautions.



Note: *Ensure that users log-out of the Touch Screen Controller before powering down or all entered data from the latest session will not be saved. (refer to [section 7.2](#)). The system is defaulted **NOT** to save any data when using the system logged in as 'Guest' regardless of logging out or not.*



Tools Required: Locking Hub Key (supplied)
#2 Philips Head Screwdriver (not supplied)
Torque tool (not supplied)

**LED Modules, Drivers and Dichroics are shipped in protective ESD bags.
LED Modules are shipped with a protective lens cap covering the LED lens.**

Ensure the system is OFF and the AC power cord is unplugged from the power source. Allow system to cool for 5 minutes before removing the housing.

Using the locking hub key supplied, rotate the green locking hubs 90 degrees and remove the locking hubs. Holding the XLED1 housing at the back, slide the XLED1 housing up and back (away from the fascia) for removal. The locking hub key can be stored on the locking hub key hanger, located on the back panel of XLED1.

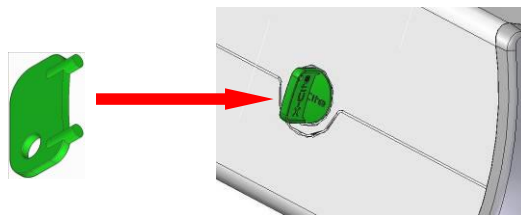

Figure 31 Locking Hub

Replacement LED Modules are shipped with their unique Drivers. Both components must be replaced at the same time. Refer to [Figure 32](#).



Note: Remove the corresponding Dichroic before removing the LED module and driver to prevent accidental contact with the Dichroic. Refer to [section 11](#).

To remove the LED Module and Driver unscrew the Philips-Head screws and remove Module and Driver.



Caution: Do not touch the LED lens surface. Skin oils and scratches can cause the optical output to decrease.

Firstly, remove the protective LED lens cap if present on the new LED module. To replace the LED Module and Driver align the LED Module and Driver male pins with the female socket connection and gently push down into place. Tighten the Philips-Head screws until a positive force is felt. **DO NOT OVER TIGHTEN THE SCREWS. (If using a calibrated torque-meter, Excelitas Technologies recommends a torque value of 5.7 lb-in/± 0.3 lb-in.)**

Replace the Dichroic (refer to section 11).

If there is a mismatch installation of either standard powered or high powered Drivers, the corresponding LED will not operate.

Replace the XLED1 housing ensuring a snug fit. Insert the locking hubs and using locking hub key supplied, rotate the green locking hubs to the locked position. Return the locking hub key to the locking hub key hanger, located at the rear of the system. The system will not allow the main power switch to function if the unit cover is not replaced properly.

Note: For assistance in determining the appropriate positions for Modules and Dichroics visit:

<http://www.excelitas.com/Pages/Product/X-Cite-LED-Module-Configurator.aspx>

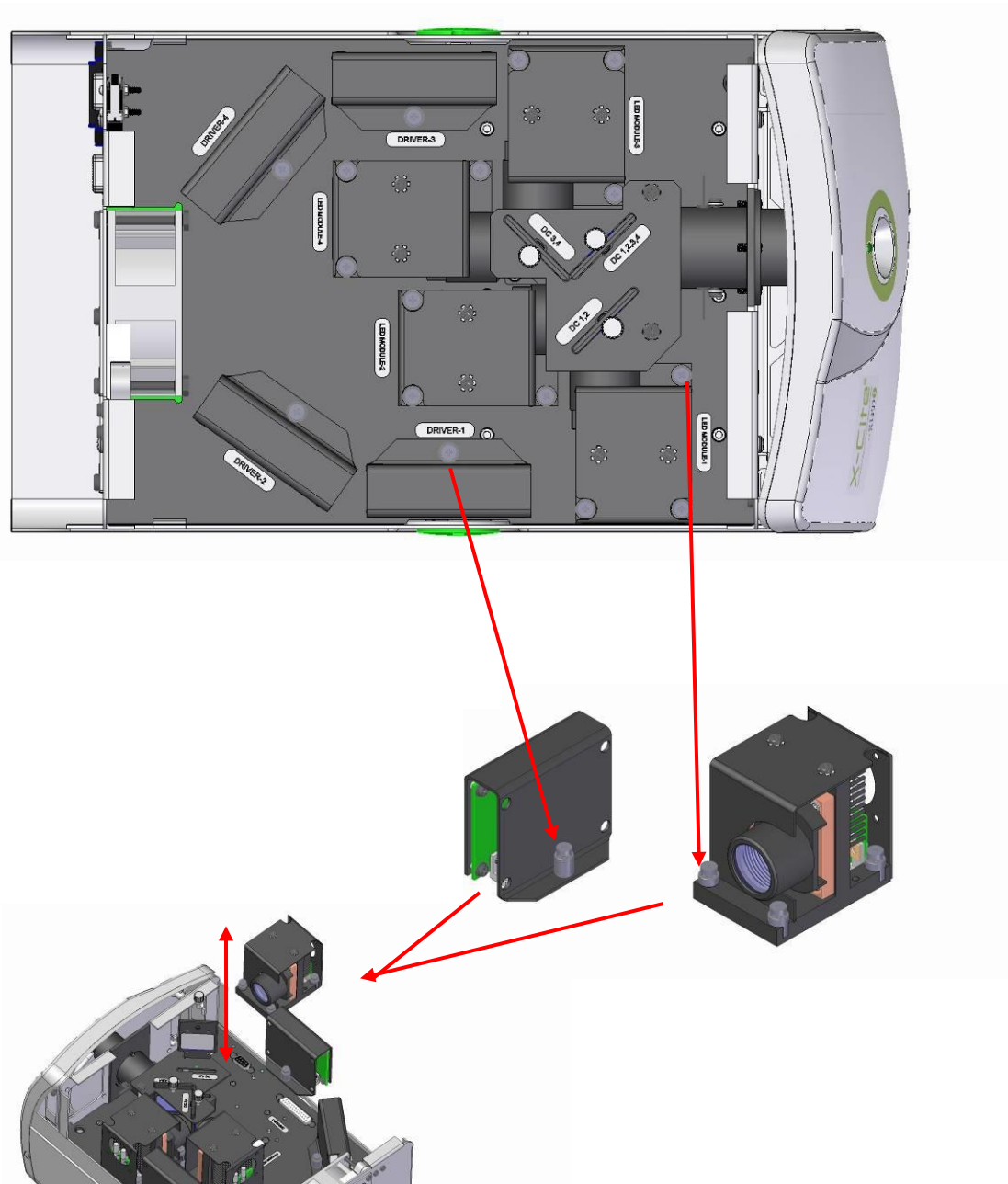

Figure 32 LED Module and Driver Replacement

11. Dichroic Replacement



CAUTION

To protect the LED Module, Driver and system from electrostatic discharge (ESD) related damage, which can disable the system, cause latent defects or permanent damage, or require repair by service technicians, please take the following ESD prevention steps:

- Ensure the unit is unplugged
- Ensure you are properly grounded, ideally by using an ESD grounding strap attached to an ESD protective surface.

Refer to [section 2.3](#) for principles of ESD and additional ESD precautions



Note: Ensure the users **log-out** of the Touch Screen Controller before powering down or all entered data from the latest session will not be saved. (refer to [section 7.2](#)). The system is defaulted **NOT** to save any data when using the system logged in as 'Guest' regardless of logging out or not.



Tools Required: Locking Hub Key (supplied)

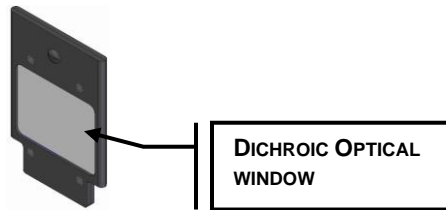

Caution:

The Dichroic optical window operational life can be significantly shortened if it is handled incorrectly. Do not touch the window surface. Skin oils and scratches can cause the window to fail prematurely. Refer to [section 12.3](#) for handling and cleaning instructions.

Ensure the system is OFF and the AC power cord is unplugged from the power source.

Using the locking hub key supplied, rotate the green locking hubs and remove the XLED1 housing, refer to [section 0](#).



Note: When replacing the Dichroic remove and replace one at a time.

Remove the plastic locking screw and gently pull out the module, avoid touching the Dichroic optical window with fingers, microscope immersion oil, or any abrasive object. Refer to [section 12.3](#) for handling and cleaning instructions. Note the orientation of the Dichroic when removing, there is a notched cut-out on the top plate which allows the Dichroic's orientation key to pass through, subsequently preventing the Dichroic from being replaced incorrectly. Refer to [Figure 33](#).

Replace the Dichroic by inserting through the slot and lightly press down until a positive force is felt. Hand tighten the locking screw, **do not use** mechanical tooling such as screw drivers, pliers etc.

If the Dichroic is inserted incorrectly, the module's orientation key (located on the module frame), will not pass through the cut-out on the top plate resulting in an unseated Dichroic.

Replace the XLED1 housing ensuring a snug fit. Using the locking hub key supplied, rotate the green locking hubs to the locked position. Return the locking hub key to the locking hub key hanger, located at the rear of the system. The system will not allow the main power switch to function if the housing is not replaced properly.

When changing a Dichroic the Edge value must be manually entered into the system. Refer to [section 7.6](#) to change the Edge value, touch on the Dichroic to see the pop-up window, touch the top tab of the window and an edit screen will appear. Type in the new Edge value and press "GO" to return to the maintenance screen. The Edge value is printed on the Dichroic.

The Reflect and Transmit values in the pop-up window will be automatically populated if using the GUI. Refer to [section 6.4](#).

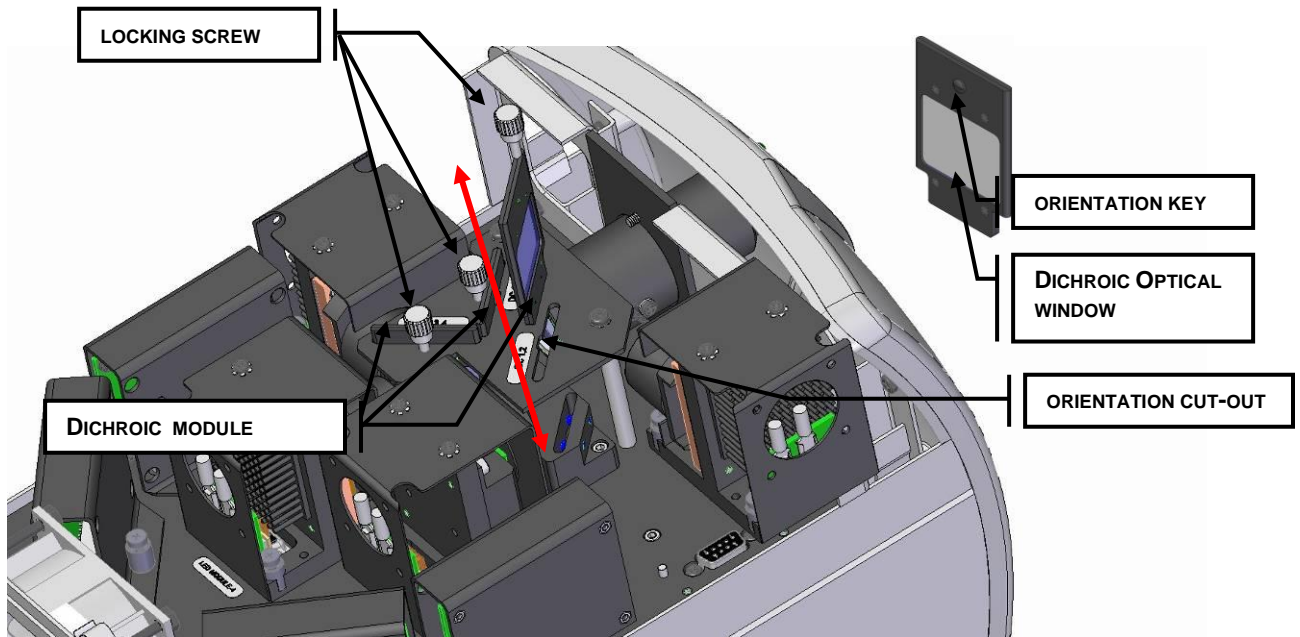

Figure 33 Dichroic Replacement

12. Routine Care and Maintenance



To protect the system from electrostatic discharge (ESD) related damage, which can disable the system, cause latent defects or permanent damage, or require repair by service technicians, please take the following ESD prevention steps:

- Ensure the unit is unplugged
- Ensure you are properly grounded, ideally by using an ESD grounding strap attached to an ESD protective surface.

Refer to [section 2.3](#) for principles of ESD and additional ESD precautions



Caution: Routine maintenance should only be completed by qualified technical personnel to avoid risk of injury to the end user.



Warning: Use UV eye and skin protection during servicing if access to the UV LED Modules is required during system operation.

12.1 General

Operate the unit in a well ventilated area with at least 50mm clearance on all sides to allow adequate space for the air vents located on the bottom of the unit.

Always connect the XLED1 external power module AC supply cord to a grounded outlet (earthed mains) only.

When necessary, clean the aperture of the Light Guide using an optical cleaning solution. Refer to [section 12.5](#).

12.2 Cleaning Procedure, XLED1 & Touch Screen Controller:

Ensure the XLED1 master power switch is in the off position and the AC power cable is unplugged.

Use a mild soap solution as the cleaning media.

Dampen a clean lint free cloth, tissue or swab with the mild soap solution and wipe the exterior of the housing. Avoid excessive moisture when wiping in the air vent areas.

Using a new dampened tissue (or pre-saturated tissue), clean the Touch Screen Controller display by gently wiping the surface with one continuous stroke in one direction.



Note: Never apply a dirty tissue or swab to the display of the Touch Screen Controller

Inspect the display to verify no residue is present.

Note: Regular cleaning of the display is recommended for optimal performance.



CAUTION: Do not use any alcohol based or acetone based solutions for cleaning the XLED1 or the Touch Screen Controller.

12.3 Handling and Cleaning of the LED Lens Assembly

Cleaning of the lens assembly is not generally required. However, if any visible contamination or finger prints appear in the lens surface, the contaminants may cause reduced light output. Light output degradation may also result from scratches, digs and other damage on the lens surface. Refrain from touching the optical window with any foreign object which could scratch the optical window.



Caution: Do not touch the LED lens surface. Skin oils and scratches can cause the optical output to decrease.

Cleaning Procedure for LED Lens Assembly

- Improper handling and cleaning practices can damage lens surface which are utilized in this assembly. Proper handling and cleaning technique should be adhered to. Below are the recommended procedures for cleaning of the lens assembly.

Handling:

- Always handle the lens assembly by the metal frame; never touch the lens surface with your fingertips. The moisture or oils on your fingertips can damage the lens surface. Fingerprints left on a lens surface for an extended period of time can become a permanent stain. Even if you are wearing gloves, avoid touching the lens surface.
- Never handle the lens assembly with metal implements or tweezers.
- To store lens assemblies, wrap them individually in a clean, ESD safe bag and store in a safe, dry place.
- Never store multiple unwrapped lens assemblies in the same bag, as they may become damaged if they come in contact with each other.

Cleaning Materials:

The following materials are recommended for cleaning the lens assembly.

- Rubber Bulb Dust Blower (non-pressurized).
- Lint-free lens tissue, lint-free cotton swabs, lint or powder-free gloves or finger cots.
- An organic solvent, such as reagent-grade isopropyl alcohol or lens cleaning solution.

Note: Avoid using any type of pressurized air/nitrogen systems for cleaning as there is a possibility of leaving an oil or chemical film on the lens surface.



Lens Assembly Cleaning Procedure:

- Wear powder free latex gloves or finger cots to protect hands from solvents and prevent lens from contamination.
- Blow off dirt and dust on lens surface with rubber dust blower.
- Use a lens tissue or a lint-free cotton swab. Saturate the lens tissue or swab with organic solvent.



CAUTION: Before using any solvent, consult the manufacturer's Materials Safety Data Sheets (MSDS) and your internal Health and Safety Advisor for proper handling and storage.

Note: Never re-install the lens assembly before the solvent has evaporated.

12.4 Handling and Cleaning of the Dichroic

Cleaning of the Dichroic is not generally required. However, if any visible contamination or finger prints appear in the Dichroic optical window, the contaminants may cause reduced light output and further damage to the system. Light output degradation may also result from scratches, digs and other coating damage on the Dichroic window surface. Refrain from touching the optical surface with any foreign object which could scratch the optical window.

Cleaning Procedure for Dichroic

- The Dichroic includes a coated substrate (Dichroic optical window) and module frame assembly. Improper handling and cleaning practices can damage surfaces or coatings which are utilized in this assembly. Note that damage to the surface of the Dichroic coating can degrade the light output performance. Proper handling and cleaning technique should be adhered to. Below are the recommended procedures for cleaning of the Dichroic.

Handling:

- Always handle the Dichroic by the metal frame; never touch the Dichroic optical window assembly with your fingertips. The moisture or oils on your fingertips can damage the coating of the glass in the optical window. Fingerprints left on an optical surface for an extended period of time can become a permanent stain. Even if you are wearing gloves, avoid touching the optical surface.
- Never handle the Dichroic optical window with metal implements or tweezers.
- To store Dichroics, wrap them individually in a clean, protective ESD bag and store in a safe, dry place.
- Never store multiple unwrapped Dichroics in the same bag, as they may become damaged if they come in contact with each other.

Cleaning Materials:

The following materials are recommended for cleaning the Dichroic.

- Rubber Bulb Dust Blower (non-pressurized).
- Lint-free lens tissue, lint-free cotton swabs, lint or powder-free gloves or finger cots.
- An organic solvent, such as reagent-grade isopropyl alcohol or lens cleaning solution.



Note: Avoid using any type of pressurized air/nitrogen systems for cleaning as there is a possibility of leaving an oily or chemical film on the Dichroic surface.

Dichroic Optical Window Cleaning Procedure:

- Wear powder free latex gloves or finger cots to protect hands from solvents and prevent window from contamination.
- Blow off dirt and dust on glass surface with rubber dust blower.
- Use a lens tissue or a lint-free cotton swab. Saturate the lens tissue or swab with organic solvent.



CAUTION: Before using any solvent, consult the manufacturer's Materials Safety Data Sheets (MSDS) and your internal Health and Safety Advisor for proper handling and storage.

Note: Never re-install the Dichroic before the solvent has evaporated

12.5 Tips to Prevent Premature Degradation of Light Guides

Liquid Light Guides have a typical useful life of 2-3 years when installed and handled properly. The formation of bubbles is one of the most common reasons for a Light Guide to degrade prematurely and result in a reduction in illumination intensity. Bubbles form without warning, usually due to overheating and/or mechanical stress to the Light Guide. Below are some simple tips to avoid overheating and stressing the Light Guide.

The Light Guide has a minimum bend radius of 1.6 inches (40.0mm). Bending or coiling the Light Guide tighter than this radius will result in permanent damage to the Light Guide.

Make sure the Light Guide is cooled properly during use, and prevent overheating:

- a. Always fully insert the Light Guide into XLED1: this ensures contact with a heat sink to conduct heat away from the Light Guide.
- b. Never obstruct the air vents on XLED1. Vents are located at the rear and underside of the unit.
- c. Do not remove the rubber feet on XLED1 or otherwise reduce/block the space between the bottom of the unit and bench top. This may compromise airflow through the unit.
- d. Ensure that the air being used to ventilate XLED1 is approximately “room temperature” (e.g. do not place the X-Cite® unit on top of another heat-producing instrument).
- e. If a heated environmental chamber (or incubator) is being used for live cell imaging, make sure that XLED1 and the Light Guide are located outside of the chamber (or incubator).

Do not expose the Light Guide to extreme temperatures (above 35°C, below -5°C) for extended periods of time during use, transport or storage; this may cause degradation of the seals and allow air bubbles to form in the liquid.

Never kink, bend, crush, or stretch the Light Guide; this type of mechanical stress may cause bubbles to form in the liquid and/or damage to the outer sheath.

- a. Always allow adequate clearance between the Light Guide port of XLED1 and other objects to prevent excessive bending.
- b. Place XLED1 close enough to the microscope so that there is some slack in the Light Guide and no sharp bends.

Never leave an end cap on the output end of the Light Guide when the other end is connected to XLED1; if the unit is turned on in this condition, the cap will overheat, melt and/or permanently discolour the quartz end of the Light Guide.

While XLED1 is on but not in actual use (i.e. during sample preparation, or between time lapse time points) it is recommended to disable the LED source by depressing (turning off) the LED “ON/OFF” button (refer to [Figure 1](#)) or through the GUI Control Panel (refer to [section 6.1](#)) or through the Touch Screen Controller, (refer to [section 7.2](#)) this reduces unnecessary photon load on the liquid Light Guide. (Using only the shutter/stop in the microscope itself protects the specimen, but energy is still passing through the Light Guide).

What does a bubble look like?

Depending on the size and location in the Light Guide, a bubble may or may not be obvious. To check for bubbles:

Disconnect the LLG from the XLED1 and microscope adapter.

Hold one end towards a bright window or overhead room light - DO NOT use the XLED1 or any other focused light source for this test!

Look at the quartz at the other end of the LLG.

- a. Bubble-free: quartz end will appear as a bright, solid circle; you may also be able to see a thin circular outline at the quartz/liquid interface.
- b. Bubbles at/near the quartz end: appear as dark spots, as small as 0.5mm in diameter or even as larger more defined spheres.
- c. Bubbles in the middle of the Light Guide: may not be well-defined spots, but will appear as dark shadows.
- d. In extreme cases, where the bubble is blocking the entire diameter of the Light Guide, no light will come through, even when pointing the distal end at a light source.

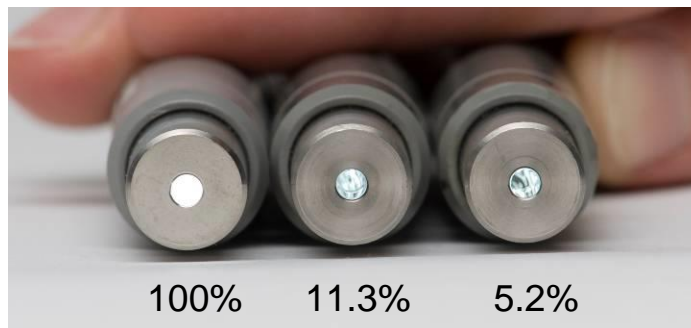

Appearance and % output of Light Guides with bubbles relative to an LLG without bubbles (100%).

Can a bubbled Light Guide recover?

Light Guides with small bubbles can sometimes recover. Disconnect the Light Guide from the XLED1, and leave the Light Guide undisturbed on a shelf for 1-2 weeks at temperatures between 2°C – 20°C. For this to be effective, it is important to catch the bubble when it is small.

When should Light Guides be replaced?

It is usually time to replace a Light Guide when:

- a. Dark or uneven areas become visible in the field of view (a bubble is blocking part of the light).
- b. A section of the Light Guide becomes noticeably warmer than the rest of the guide (a bubble is blocking transmission of light, forcing the Light Guide to absorb the energy).
- c. It is 2-3 years old OR has been in use for 4000-6000 hours.

13. Troubleshooting Symptom/Possible Cause

CAUTION: Service to be completed by qualified technical personnel only!

If the XLED1 fails to POWER up or function properly, use the following checklist to eliminate the most common causes of problems. Check for the following:

1. The power supply cord is securely connected to a grounded (earthed mains socket) functional 3-pin outlet.
2. The power supply cord is securely connected into the 3-pin outlet on the rear of the controller unit.
3. Ensure the housing is installed correctly.

If the light intensity is too low, check for the following:

1. Ensure Power is off. Verify that the emitting end of the Light Guide has been properly cleaned.
2. Verify that the intensity level of the LED Modules are set correctly, (GUI Control Panel – Main LED Screen) or (Touch Screen Controller Main LED screen) and the LEDs have been enabled and triggers are off.
3. Ensure Dichroic Modules are installed correctly.
4. Check the Dichroic Edge value matches the actual value printed on the Dichroic:
 - a. Turn off system (ensuring to properly log out).
 - b. Open the housing and remove each Dichroic module one at a time taking note of the Dichroic Edge value printed on the Dichroic module.
 - c. Install the housing.
 - d. Start up system and navigate to the maintenance screen. Select each Dichroic green lit module and compare pop-up screen edge value to the actual printed value.

If the optional Touch Screen Controller display does not illuminate:

1. Verify that the Touch Screen Controller is plugged into the XLED1 and the XLED1 turned on.
2. Verify the screen brightness is turned up ([section 7.9 Touch Screen Controller System Information Screen](#)).
3. Verify screen Time-out mode setting ([section 7.9 Touch Screen Controller System Information Screen](#)).

Touch Control/Screen Accuracy:

1. If the touch control is lagging, navigate to the System Information Screen to run a screen calibration for screen accuracy, follow these steps:
 - LOG IN
 - Main LED Screen
 - Press the Maintenance Screen pad
 - Press the System Pad
 - Press the Align Touch Screen Pad (refer to [section 7.9](#))

14. Technical Specifications

LED Modules:

Central Wavelength/FWHM: Refer to <http://www.excelitas.com/Pages/Product/X-Cite-LED-Module-Configurator.aspx> for available wavelengths

Dimensions: 50mm (W) x 72mm (D) x 71mm (H)

Connections: HD-DB-15-style through connector on module underside

Driver Modules:

Quantity: 2 types, high power and standard power

Max Power Delivery: 75W per driver/12.5V max/14A max

Dimensions: 71mm (W) x 33mm (D) x 65mm (H)

Connections: DB-25-style through connector on module underside

Dichroic Combiner Modules:

Dimensions: 38mm (W) x 55mm (H) x 3mm (D)

XLED1 System:

Power Consumption: <420W max

Supply: Universal input: 100-240Volts AC, 50-60Hz

100V: 4.2A max

240V: 1.8A max

Fuse Rating: F6.3A, 250V (X2)

Front Panel Indicators: Light Guide Indicator: Green = Light Guide Present
Red = Light Guide not Present
Yellow = LED is in Live Cell Mode

LED (ON/OFF Button) Indicator:

Green = any LED module is ON

OFF= all LED Modules are OFF

Front Panel Switches: LED ON/OFF: green illumination = ON

LED ON/OFF: no illumination = OFF

AC Power Switch

Front Panel Ports: Light Guide Optical Tube

Rear Panel Ports: AC inlet – 3 terminal ground

USB type-B female (supports 2.1 and below)

Trigger Input (5V, 6.5mA max)

Sync Output (5V, 100µA max)

Touch Screen Controller Port

Internal Optical Layout:	4-port optical table with capacity for up to: <ul style="list-style-type: none"> • 4 x LED Modules • 3 x Dichroic Combiner Modules • 4 x Driver Modules
Triggering:	Internal/ External User-defined per channel Global trigger input User-defined free-running or single shot pulse modes Internal triggering generated from Pulse Generator Module, (min pulse width 10µs, max 18 hours) Sync-out with delay options
Switching Speed:	Between wavelengths – instantaneous Pulsing single wavelength – 10µs
Overall Dimensions:	216mm (W) x 387mm (D) x 205mm (H)
Weight:	<7.5kg, <16.5lbs max.
Maximum Noise Level:	49dBA at a distance of 1m.
Optional Touch Screen Controller:	
Screen:	Medical/industrial grade 7inch TFT viewable diagonal Resistive touch-screen with 16:9 aspect ratio and LED backlight with adjustable intensity
Resolution:	800 x 480 pixels
Display Viewing Area:	152.4mm (W) x 91.44mm (H)
External Dimensions:	197mm (W) x 136mm(D) x 63mm (H) without legs extended
Program:	Excelitas Technologies proprietary graphical user interface
Connectivity:	~2.5m connectorized power and data combo cable
Power:	<10 watts, 5.2V max
LED Intensity Control:	5-100%, in 0.1% increments

15. Environmental Conditions

Operating Conditions

Ambient Temperature: 5°C to 35°C
Altitude: 2000m max.
Atmospheric Pressure: 700 to 1060 hPa
Relative Humidity: 15% to 85% (non-condensing)
Installation Category: II
Pollution Degree: 2

Transport and Storage Conditions

Temperature: -10 to +70°C
Relative Humidity: 10% to 90%
Atmospheric Pressure: 500 to 1060 hPa

16. Regulatory Compliance

Product Safety and Electromagnetic Compatibility:

The X-Cite XLED1 has been tested and found to comply with product safety and electromagnetic compatibility requirements. For a complete list of tests and for certification details, please contact your X-Cite representative or visit <http://www.excelitas.com/Pages/Product/X-Cite-XLED1.aspx>.

CE Marking:

As per Council Directives:

2006/95/EC	Low Voltage Directive
2004/108/EC	EMC Directive
2012/19/EU	WEEE Directive
2011/65/EU	RoHS Directive



FCC PART 15, Subpart B, Class A - Unintentional Radiators.

FCC Class A Digital Device or Peripheral – Information to User

NOTE

This equipment has been tested and found to comply with the limits for a Class A digital device, pursuant to part 15 of the FCC Rules. These limits are designed to provide reasonable protection against harmful interference when the equipment is operated in commercial environment. This equipment generates, uses, and can radiate radio frequency energy and, if not installed and used in accordance with the instruction manual, may cause harmful interference to radio communications. However, there is no guarantee that interference will not occur if installed in a residential area. If this equipment does cause harmful interference to radio

or television reception, which can be determined by turning the equipment off and on the user is encouraged to try to correct the interference by one or more of the following measures:

- Reorient or relocate the receiving antenna.
- Increase the separation between the equipment and receiver.

WARNING

Changes or modifications not expressly approved by Excelitas Technologies could void the user's authority to operate the equipment. Use only the shielded power supply cord supplied with the **XLED1 System**.

WEEE Directive (2012/19/EU)



The symbol above indicates that this product should not be disposed of along with municipal waste, that the product should be collected separately, and that a separate collection system exists for all products that contain this symbol within member states of the European Union.

- The equipment that you bought has required the extraction and use of natural resources for its production. It may contain hazardous substances that could impact health and the environment.
- In order to avoid the dissemination of those substances in our environment and to diminish the pressure on the natural resources, we encourage you to use the appropriate take-back systems. Those systems will reuse or recycle most of the materials of your end life equipment in a sound way.
- The crossed-out wheeled bin symbol indicated above invites you to use those systems.
- If you need more information on the collection, reuse and recycling systems, please contact your local or regional waste administration.

China RoHS:

The following table contains substance information for the XLED1 System as required by China RoHS regulations:

Names and Content of Toxic and Hazardous Substances or Elements

Parts Name	Toxic and Hazardous Substances or Elements					
	Pb	Hg	Cd	Cr6+	PBB	PBDE
LED Modules and Dichroics	x	o	x	o	o	o
System Controller/Power Supply	o	o	o	o	o	o

o: Indicates that this toxic or hazardous substance contained in all of the homogeneous materials for this part is below the limit requirement in SJ/T11363-2006

x: Indicates that this toxic or hazardous substance contained in at least one of the homogeneous materials used for this part is above the limit requirement in SJ/T11363-2006 (Enterprises may further provide in this box technical explanation for marking “x” based on their actual conditions.)

Table 10 China RoHS

17. Warranty

See [section 18](#) for additional warranty coverage. Excelitas Technologies warrants the original purchaser for a period of one (1) full year, calculated from the date of purchase, that the equipment sold is free from defects in material and workmanship. All repairs are warranted for 90 days.

In the event of a claim under this warranty, the equipment is to be sent postage and carriage paid to the Excelitas Technologies Service Center. Returned equipment will not be received without a Return Authorization (RA) Number, issued by the appropriate Service Center.

In order for us to serve you better, include a written description of the fault and the name and telephone number of a contact person who may be contacted for additional service related questions.

Any claims for units received with defects in material or workmanship must be reported to an authorized Excelitas Technologies Service Center within 30 days from the original date of receipt and returned within 30 days of reporting to a an authorized Excelitas Technologies Service Center. Excelitas Technologies will repair or replace these reported defects free of charge. The equipment must be sent postage and carriage paid.

Package the equipment in its original shipping case or as appropriate to prevent damage during transport.

In the case of damage caused by wear and tear, careless handling, neglect, by the use of force or in the case of interventions and repairs not carried out by a Excelitas Technologies Authorized Service Center, the warranty ceases to be valid. This warranty may not form the basis for any claims for damages, in particular not for compensation of consequential damages. This warranty is not transferable.

No warranty is extended to perishable items (if purchased separately or included in systems). These may include, but are not limited to, fuses, air filters, cables, Light Guides, light lines and Light Guide adapters. Refer to [Table 11](#) System Components Warranty.



Note: Removal or interfering of the tamperproof label located on the underside of the XLED1 will result in Void Warranty.

18. Warranty Table

System Component	Warranty	Warranty void if...
X-Cite® XLED1 – Main System and Drivers	1 year	<ul style="list-style-type: none"> • The unit has been subjected to misuse or mishandling • The unit has been opened or tampered with
X-Cite® XLED1 Optional Touch Screen Controller	1 year	<ul style="list-style-type: none"> • The unit has been subjected to misuse or mishandling • The unit has been opened or tampered with • LCD display damage (physical) • Cable damage due to mishandling
All LED Modules	20,000 hrs or 3 years, whichever comes first	<ul style="list-style-type: none"> • HD-15 pin connector damage • Lens damage due to misuse or mishandling • Cable damage due to misuse or mishandling • Module has been opened or tampered with • The LED Drivers are not included (1 year warranty applies here) • The Dichroics are not included (1 year warranty applies here)

Table 11 System Components Warranty

19. Component Number Table

Part No.	Description
010-00322R	X-Cite® XLED1 Live Cell configuration includes: - X-Cite® XLED1 unit - BLX, BDX, BGX, GYX LED modules & appropriate dichroics - Excitation Filter Holders (set of 4) - 3mm x 1500mm Liquid Light Guide, Microscope Adaptor - Live Cell Mode (refer to section 8.0)
010-00323R	X-Cite® XLED1 Fixed Cell #1 configuration includes: - X-Cite® XLED1 unit - UVA, BDX, GYX, RLX LED modules & appropriate dichroics - Excitation Filter Holders (set of 4) - 3mm x 1500mm Liquid Light Guide, Microscope Adaptor
010-00324R	X-Cite® XLED1 Fixed Cell #2 configuration includes: - X-Cite® XLED1 unit - UVX, BDX, GYX, RLX LED modules & appropriate dichroics - Excitation Filter Holders (set of 4) - 3mm x 1500mm Liquid Light Guide, Microscope Adaptor
010-00288R	X-Cite® XLED1 illumination unit only includes: - GUI Control Panel - 3mm x 1500mm Liquid Light Guide, Microscope Adaptor
010-00278R	X-Cite® XLED1 Optional Touch Screen Controller
020-00792	Locking Hub Key comes with Locking Hub Key Hanger
019-00175R	X-Cite® XLED1 Excitation Filter Holders (set of 4)
805-00069R	1mm x 1000 mm X-Cite® XLED1 quartz fibre (SMA)
805-00072R	1mm x 2000 mm X-Cite® XLED1 quartz fibre (FC)
018-00491R	X-Cite® XLED1 trigger cable (DB15 to BNCX5)

Table 12 Component Part Numbers

For additional LED Wavelength Modules contact your local sales representative or visit:
<http://www.excelitas.com/Pages/Contact/Contact-Us.aspx>

For the on-line LED module/Dichroic configurator visit:
<http://www.excelitas.com/Pages/Product/X-Cite-LED-Module-Configurator.aspx>

Please ensure that you register your XLED1 at:
http://www.excelitas.com/Pages/Support/Register_OX.aspx

20. Contact Information

Excelitas Canada Inc.
2260 Argentia Road
Mississauga, Ontario
L5N 6H7 CANADA

Tel.:+1 905 821-2600

Toll.:+1 800 668-8752 (USA and Canada)

Fax:+1 905 821-2055

x-cite@excelitas.com

<http://www.excelitas.com/Pages/Product/X-Cite.aspx>

Technical Assistance:

techsupport@excelitas.com

For a complete listing of Authorized X-Cite® Distributors and Service Centers please go to the main web site: <http://www.excelitas.com/Pages/Support/Service-Centers.aspx>