



Capacitive Touch Kit For Arduino(SKU:DFR0129)

Contents

- [1 Introduction](#)
- [2 Connection Diagram](#)
- [3 Sample Code](#)

Introduction

Now, it is time to add a more fancy interactive way to your project. This DFRobot touch kit comes with three types touch sensors. An ipod style wheel touch, a keypad touch which supports backlit and a grid touch pad which can recognize something unique.

This kit utilizes the not very "latest" capacitive touch technology which make the sensing very sensitive.

The kit is designed to be compatible with Arduino.

Connection Diagram

Keypad CD

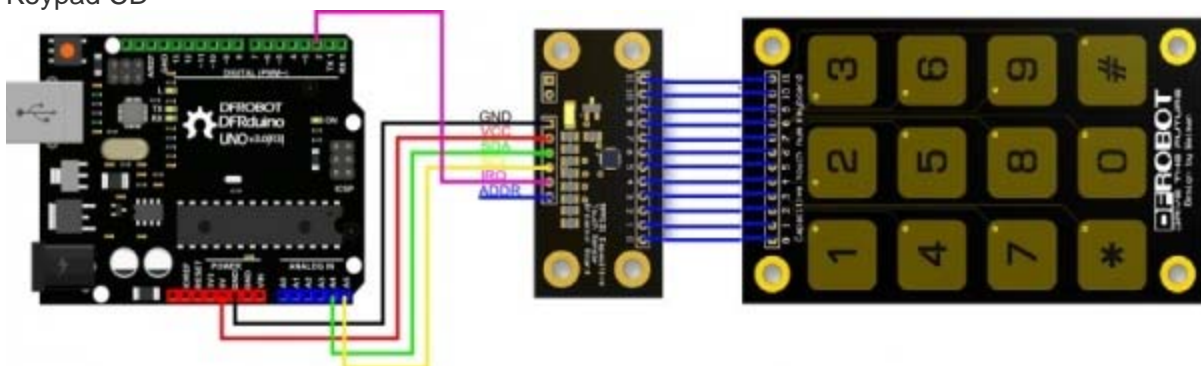

Wheel pad CD

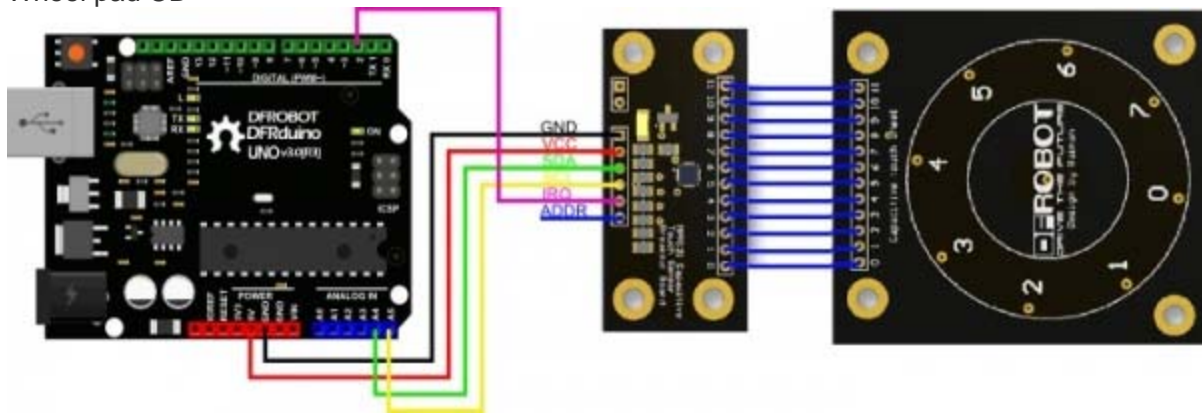

Touch pad CD

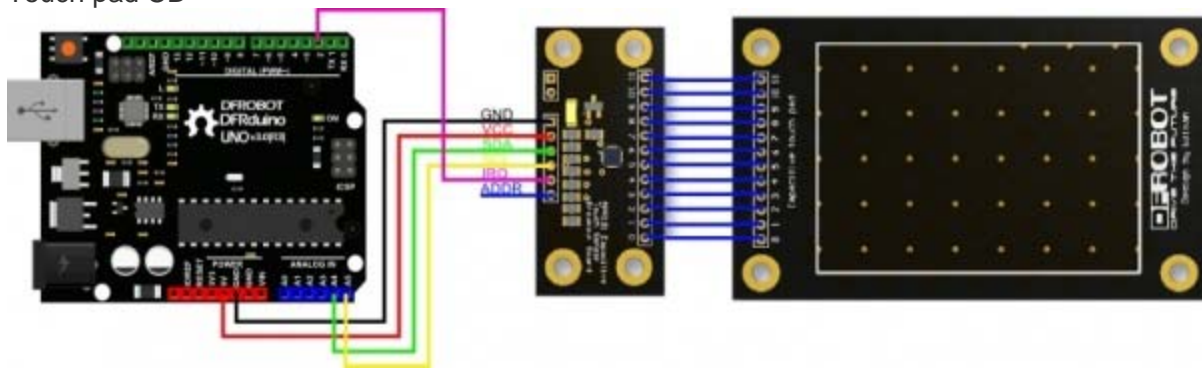

NOTE: The pin number is the same to the PCB board one.

Sample Code

Please download the [touch kit library](#) first.

This code is for WheelPad.

```
/*  
TouchWheel.pde  
MPR121 WheelPad Example Code  
  
by:Waiman Zhao  
Mail:Binpower@foxmail.com  
created on: 11/2/14
```

```
license: CC-SA 3.0

Hardware: 3.3V Arduino Pro Mini
        SDA -> A4
        SCL -> A5
        IRQ -> D2
*/

#include <Wire.h>
#include <mpr121.h>

int key = 0;

// ===== setup =====
void setup()
{
    // initialize function
    Serial.begin(19200);
    Wire.begin();
    CapaTouch.begin();

    delay(500);
    Serial.println("START");
}

// ===== loop =====
void loop()
{
    key=CapaTouch.keyPad();

    if (key==1)
```

```
{ Serial.print("wheel:");  
Serial.println("0");  
}  
  if (key==4)  
{ Serial.print("wheel:");  
Serial.println("1");  
}  
  if (key==7)  
{ Serial.print("wheel:");  
Serial.println("2");  
}  
  if (key==11)  
{ Serial.print("wheel:");  
Serial.println("3");  
}  
  if (key==2)  
{ Serial.print("wheel:");  
Serial.println("4");  
}  
  if (key==5)  
{ Serial.print("wheel:");  
Serial.println("5");  
}  
  
  if (key==8)  
{ Serial.print("wheel:");  
Serial.println("6");  
}  
  if (key==0)  
{ Serial.print("wheel:");  
Serial.println("7");  
}  
  if (key==3)  
{ Serial.print("wheel:");
```

```
    Serial.println("8");  
  }  
    delay(200);  
}
```

This code is for KeyPad.

```
/*  
  TouchWheel.pde  
  MPR121 WhellPad Example Code  
  
  by:Waiman Zhao  
  Mail:Binpower@foxmail.com  
  created on: 11/2/14  
  license: CC-SA 3.0  
  
  Hardware: 3.3V Arduino Pro Mini  
            SDA -> A4  
            SCL -> A5  
            IRQ -> D2  
*/  
  
#include <Wire.h>  
#include <mpr121.h>  
  
int key = 0;  
  
// =====  setup  =====  
void setup()  
{  
    // initialize function
```

```

Serial.begin(19200);
Wire.begin();
CapaTouch.begin();

delay(500);
Serial.println("START");
}

// ===== loop =====
void loop()
{
  key=CapaTouch.keyPad();

  if (key==11)
  { Serial.print("key:");
    Serial.println("*");
  }
  else if(key==12)
  {
    Serial.print("key:");
    Serial.println("#");
  }
  else if(key>=0){
    Serial.print("key:");
    Serial.println(key);
  }

  delay(200);
}

```

This code is for TouchPad.

```

// #
// # Editor : Jiang from DFRobot

```

```

// # Data      : 19.11.2012
// # E-Mail    : jianghao0716@gmail.com

// # Product name : Capacitive touch pad
// # Version   : 0.4
// # Power supply: 3.3v
// # Connection:
// #          SDA (MPR121) -> PIN A4 (Arduino)
// #          SCL (MPR121) -> PIN A5 (Arduino)
// #          IRQ (MPR121) -> PIN A2 (Arduino)

#include <Wire.h>
#include <mpr121.h>

int X ;          // X-coordinate
int Y ;          // Y-coordinate

// =====  setup  =====
void setup()
{
  // initialize function
  Serial.begin(19200);
  Wire.begin();
  CapaTouch.begin();

  delay(500);
  Serial.println("START");
}

// =====  loop  =====
void loop()
{
  X=CapaTouch.getX();          // Get X position.

```

```
Y=CapaTouch.getY();           // Get Y position.
if(X>=1&&X<=9&&Y>=1&&Y<=13)
{
    // Determine whether in the range.If not
    ,do nothing.
    Serial.print("X=");
    Serial.print(X);
    Serial.print("  Y=");
    Serial.println(Y);
}
delay(200);
}
```